



# 2 Percy Street, Auburn Planning Proposal Transport Impact Assessment

**Client //** Australian Turkish Maarif Foundation  
**Office //** NSW  
**Reference //** N124470  
**Date //** 19/05/17

2 Percy Street, Auburn

Planning Proposal

Transport Impact Assessment

Issue: A 19/05/17

Client: Australian Turkish Maarif Foundation  
Reference: N124470  
GTA Consultants Office: NSW

**Quality Record**

Issue	Date	Description	Prepared By	Checked By	Approved By	Signed
A	19/05/17	Final	Clifford Widjaja, Siew Hwee Kong	Siew Hwee Kong	Siew Hwee Kong	Siew Hwee Kong

# Table of Contents

---

<b>1. Introduction</b>	<b>1</b>
1.1 Background	1
1.2 Previous Studies	1
1.3 Purpose of this Report	2
1.4 References	2
<b>2. Existing Conditions</b>	<b>3</b>
2.1 Road Network	3
2.2 Traffic Volumes	5
2.3 Intersection Operation	7
2.4 Car Parking	9
2.5 Public Transport	10
2.6 Pedestrian Infrastructure	11
2.7 Cycle Infrastructure	12
<b>3. Development Proposal</b>	<b>13</b>
3.1 Land Uses	13
3.2 Mode Choice	13
3.3 Vehicle Access	13
3.4 Car Parking	14
3.5 Loading Areas	14
3.6 Pick-up/ Drop-off	14
<b>4. Car Parking</b>	<b>16</b>
4.1 Car Parking Requirements	16
4.2 Empirical Assessment of Car Parking Demand	17
<b>5. Sustainable Transport Infrastructure</b>	<b>18</b>
5.1 Bicycle Parking Requirements	18
5.2 Pedestrian and Bicycle Facilities	18
5.3 Public Transport	19
<b>6. Traffic Impact Assessment</b>	<b>20</b>
6.1 Traffic Generation	20
6.2 Distribution and Assignment	20
6.3 Traffic Impact	24
6.4 Other Developments Traffic	25
6.5 Friday Prayer Traffic	26
<b>7. Conclusion</b>	<b>27</b>

---

## Appendices

---

- A: Survey Results
- B: SIDRA INTERSECTION Results
- C: Proposed School Program

## Figures

---

Figure 2.1:	Subject Site and Its Environs	3
Figure 2.2:	Percy Street (looking north)	4
Figure 2.3:	Percy Street (looking south)	4
Figure 2.4:	Gelibolu Parade (looking east)	4
Figure 2.5:	Gelibolu Parade (looking west)	4
Figure 2.6:	St Hilliers Road (looking north)	5
Figure 2.7:	St Hilliers Road (looking south)	5
Figure 2.8:	Existing AM/ PM School Peak Hour Traffic Volumes	6
Figure 2.10:	Public Transport Network Map	11
Figure 2.11:	Extract of the Auburn Bicycle Route Map	12
Figure 3.1:	Pick-up/ Drop-off Opportunities	15
Figure 5.1:	Proposed Infrastructure Treatments for Cycle and Pedestrians	19
Figure 6.1:	Proposed Infrastructure Treatments for Cycle and Pedestrians	21
Figure 6.2:	Proposed Infrastructure Treatments for Cycle and Pedestrians	22
Figure 6.3:	Arrival and Departure Distribution of Traffic	23
Figure 6.4:	Weekday AM and PM Peak Hour Traffic Volumes plus Development Traffic	24

## Tables

---

Table 2.1:	Adjoining roads summary	5
Table 2.2:	SIDRA INTERSECTION Level of Service Criteria	7
Table 2.3:	Existing Operating Conditions	8
Figure 2.9:	Boorea Street/ St Hilliers Road/ Rawson Street Intersection Congestion due to Station Road/ Rawson Street Intersection located to the Northwest	9
Table 2.4:	Summary of AM Peak Public Parking Demand	10
Table 2.5:	Summary of PM Peak Public Parking Demand	10
Table 2.6:	Public Transport Provision	11
Table 3.1:	Indicative Schedule	13
Table 4.1:	DCP 2010 Car Parking Requirements	16
Table 5.1:	Recommended Bicycle Parking Rates	18
Table 6.1:	Future Operating Conditions	25

# 1. Introduction

## 1.1 Background

It is understood that a Planning Proposal is to be lodged with Cumberland Council (Council) to amend the existing planning controls for the site located at 2 Percy Street, Auburn.

The Planning Proposal seeks to allow additional permitted land uses for the site, including kindergarten, primary school, secondary school and administration office uses which accommodates up to 650 students. These land uses are currently prohibited under the Light Industrial Zone (IN2). It is not specifically proposed to construct any new building on the site (7,143 sq.m) but rather accommodate the additional land uses within the existing building envelope.

GTA Consultants (GTA) was commissioned by Australian Turkish Maarif Foundation in April 2017 to undertake a transport impact assessment for the proposed development.

## 1.2 Previous Studies

Several previous transport assessments have been completed as part of the broader Auburn LGA study as well as the proposed 3 storey residential aged care facility located west of the site at 9, 11 and 13 Gelibolu Parade and 2, 2A, 4 and 6 St Hilliers Road, Auburn.

Auburn LGA-wide Traffic and Transport Study (Hyder Consulting, 2012)

Hyder Consulting prepared a report in October 2012 to assess the impact of a potential increase in development capacity to accommodate additional floor space ratios (FSR) in the Auburn LGA on the surrounding road network.

This included an additional 3,238 dwellings and 153,030sq.m of mixed use podium gross floor area (GFA) for employment uses, generating 3,700 to 4,900 additional vehicle trips in one peak hour. The report provides recommendations on potential upgrading works at critical intersections required to minimise impact from increased FSR.

The report indicated that the intersection of Boorea Road/ St Hilliers Road/ Rawson Street will operate at Level of Service (LOS) F and identified the following road capacity improvements to cater for the additional traffic demand in 2021:

- Conversion of the four-leg intersection to a three-leg T-junction by closing the St Hilliers Road south approach as this approach carries small traffic volumes (less than 20 vehicles in one hour).
- Provision of an alternative access for traffic to/from St Hilliers Road south via North Parade-Dartbrook Road or North Parade-Percy Street.
- Provision of dual left turn signalised slip lanes on the Rawson Street western approach onto St Hilliers Road

Traffic Impact Assessment for 9, 11 and 13 Gelibolu Parade and 2, 2A, 4 and 6 St Hilliers Road, Auburn (Jacobs, 2015)

Jacobs prepared a Traffic Impact Assessment Report in May 2015 for a development west of the subject site, at 9, 11 and 13 Gelibolu Parade and 2, 2A, 4 and 6 St Hilliers Road, Auburn. The proposed development involved the demolition of existing buildings and construction of a 3-storey residential aged care facility comprising 102 beds and a neighbourhood shop, with basement parking (DA189/2015). The report states that the peak trip generation (based on

parking demand) will occur between 2pm and 3pm during a shift changeover with a total of 44 vehicle trips per hour. The report also concluded that there is more than sufficient on-street parking to accommodate the staff changeover period.

### 1.3 Purpose of this Report

This report sets out an assessment of the anticipated transport implications of the proposed development, including consideration of the following:

- i existing traffic and parking conditions surrounding the site
- ii suitability of the proposed parking in terms of supply (quantum) and layout
- iii service vehicle requirements
- iv pedestrian and bicycle requirements
- v the traffic generating characteristics of the proposed development
- vi suitability of the proposed access arrangements for the site
- vii the transport impact of the development proposal on the surrounding road network.

### 1.4 References

In preparing this report, reference has been made to the following:

- o an inspection of the site and its surrounds
- o Cumberland (previously Auburn) Council Development Control Plan (DCP) 2010
- o RMS Guide to Traffic Generating Developments October 2002
- o RMS Guide to Traffic Generating Developments – Technical Direction August 2013
- o Australian Standard/ New Zealand Standard, Parking Facilities, Part 1: Off-Street Car Parking AS/NZS 2890.1:2004
- o Australian Standard, Parking Facilities, Part 2: Off-Street Commercial Vehicle Facilities AS 2890.2:2002
- o Australian Standard / New Zealand Standard, Parking Facilities, Part 6: Off-Street Parking for People with Disabilities AS/NZS 2890.6:2009
- o traffic surveys undertaken by Matrix Traffic and Transport Data on Tuesday 2 May 2017 as referenced in the context of this report
- o traffic and car parking surveys undertaken by GTA on Tuesday 2 May 2017 as referenced in the context of this report
- o proposed school program prepared by Architecture Design Studio, dated 09 May 2017
- o other documents and data as referenced in this report.

## 2. Existing Conditions

The subject site is located at 2 Percy Street, Auburn. The site of approximately 7,143 sq.m has frontages of 140 metres, 130 metres and 120 metres to Percy Street, Gelibolu Parade and St Hilliers Road respectively. The site currently has a land use classification as Light Industrial Zone (IN2) and is occupied by a two-level office building, tenanted by the Master Plumbers (and Mechanical Contractors) Association of NSW and the Master Plumbers College of Excellence.

The surrounding properties predominantly include industrial, residential and community land uses. The location of the subject site and its surrounding environs is shown in Figure 2.1.

Figure 2.1: Subject Site and Its Environs

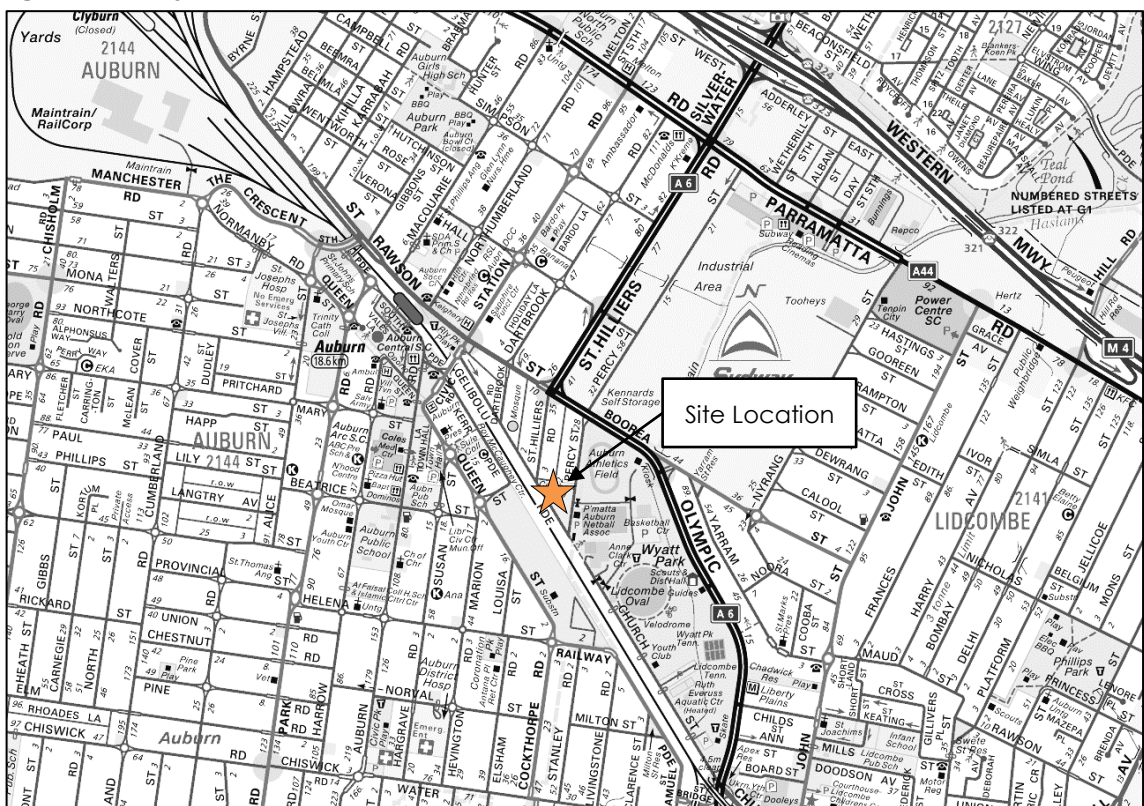

Basemap source: Sydway Publishing Pty Ltd

### 2.1 Road Network

#### 2.1.1 Adjoining Roads

##### Percy Street

Percy Street is classified as a local road and is aligned in a north-south direction in the vicinity of the site. It is a two-way road configured with one lane in each direction within a 12-metre-wide carriageway.

Kerbside parking is permitted on both sides of the road, with parallel parking on the western side and a mix of 90-degree and parallel parking along the eastern side of the road.

Percy Street is shown in Figure 2.2 and Figure 2.3.

**Figure 2.2: Percy Street (looking north)**



**Figure 2.3: Percy Street (looking south)**



### Gelibolu Parade

Gelibolu Parade functions as a local road and in the vicinity of the site is aligned in a northwest-southeast direction. It is a two-way road configured with one lane in each direction within a 10-metre-wide carriageway.

Kerbside parking is permitted along the northern edge of Gelibolu Parade between Percy Street and St Hilliers Road. A mix of angled and parallel kerbside parking is permitted along Gelibolu Parade north west of St Hilliers Road.

Gelibolu Parade is shown in Figure 2.4 and Figure 2.5.

**Figure 2.4: Gelibolu Parade (looking east)**



**Figure 2.5: Gelibolu Parade (looking west)**



### St Hilliers Road

St Hilliers Road is a classified State Road (RMS controlled) and is aligned in a north-south direction. In the vicinity of the site, it is a two-way road configured with one travel lane and one kerbside parking lane in each direction. Kerbside parking is permitted on both sides of the road. The road carriageway is approximately 12 metres wide.

St Hilliers Road is shown in Figure 2.6 and Figure 2.7.



Figure 2.6: St Hilliers Road (looking north)



Figure 2.7: St Hilliers Road (looking south)



A summary of the surrounding roads is shown in Table 2.1.

Table 2.1: Adjoining roads summary

Road name	Road type	Carriageway width	Speed limit
Percy Street	Local	12 m	50 km/h
Gelibolu Parade	Local	10 m	
St Hilliers Road	State (RMS controlled)	12 m	

### 2.1.2 Surrounding Intersections

The following intersections currently exist in the vicinity of the site:

- St Hilliers Road/ Gelibolu Parade (unsignalised)
- Boorea Road/ St Hilliers Road/ Rawson Street (signalised)
- Boorea Street/ Percy Street (unsignalised).

## 2.2 Traffic Volumes

GTA Consultants commissioned traffic movement counts at the above three key intersections in the vicinity of the site on Tuesday 5 May 2017 during the following peak periods:

- 7:00am and 9:00am
- 3:00pm and 5:00pm.

The kindergarten operates from 8:30am to 3:15pm while the primary and high schools hold classes from 8:30am to 3:30pm, Monday to Friday.

Due to the operating hours of the school, the AM and PM hour traffic volumes during the following school peak periods are used for the traffic impact assessment:

- 8:00am and 9:00am
- 3:00pm and 4:00pm.

These AM and PM school peak hour traffic volumes are summarised in Figure 2.8, with full results contained in Appendix A.

Figure 2.8: Existing AM/ PM School Peak Hour Traffic Volumes

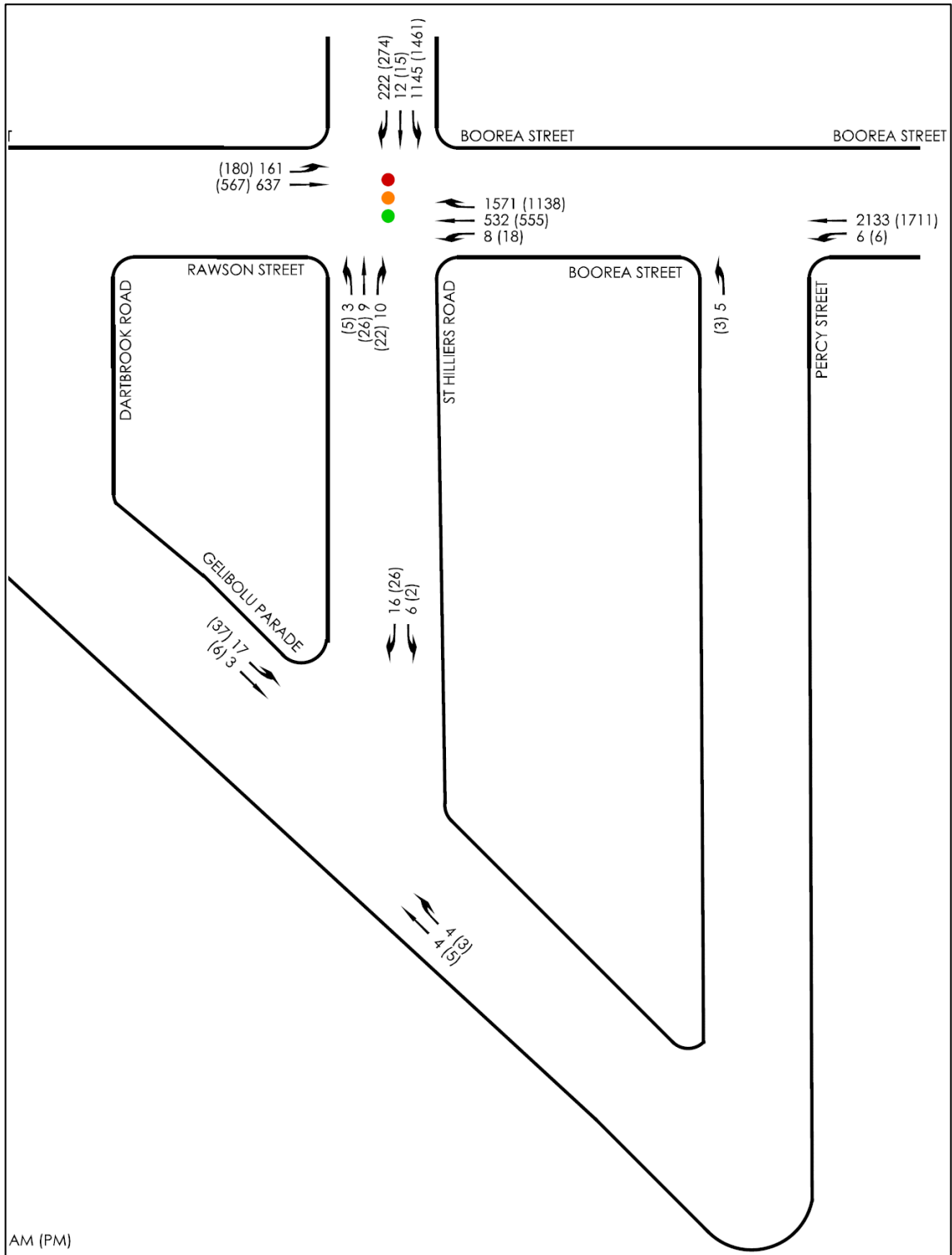

## 2.3 Intersection Operation

The operation of the key intersections within the study area have been assessed using SIDRA INTERSECTION<sup>1</sup>, a computer based modelling package which calculates intersection performance.

The commonly used measure of intersection performance, as defined by the RTA, is vehicle delay. SIDRA INTERSECTION determines the average delay that vehicles encounter and provides a measure of the level of service.

Table 2.2 shows the criteria that SIDRA INTERSECTION adopts in assessing the level of service.

**Table 2.2: SIDRA INTERSECTION Level of Service Criteria**

Level of Service (LOS)	Average Delay per vehicle (secs/veh)	Traffic Signals, Roundabout	Give Way & Stop Sign
A	Less than 14	Good operation	Good operation
B	15 to 28	Good with acceptable delays and spare capacity	Acceptable delays and spare capacity
C	29 to 42	Satisfactory	Satisfactory, but accident study required
D	43 to 56	Near capacity	Near capacity, accident study required
E	57 to 70	At capacity, at signals incidents will cause excessive delays	At capacity, requires other control mode
F	Greater than 70	Extra capacity required	Extreme delay, major treatment required

Table 2.3 presents a summary of the existing operation of the intersection, with full results presented in Appendix B of this report.

<sup>1</sup> Program used under license from Akcelik & Associates Pty Ltd.

**Table 2.3: Existing Operating Conditions**

Intersection	Peak	Leg	Degree of Saturation (DOS)	Average Delay (sec)	95th Percentile Queue (m)	Level of Service (LOS)
St Hilliers Road/ Gelibolu Parade	AM	Gelibolu Parade (SE)	0.01	5	1	A
		St Hilliers Road (N)	0.02	7	1	A
		Gelibolu Parade (NW)	0.02	7	0	A
	PM	Gelibolu Parade (SE)	0.01	5	1	A
		St Hilliers Road (N)	0.03	7	1	A
		Gelibolu Parade (NW)	0.03	7	0	A
Boorea Road/ St Hilliers Road/ Rawson Street	AM	St Hilliers Road (S)	0.15	74	6	E
		Boorea Street (SE)	0.76	29	234	C
		St Hilliers Road (NE)	0.60	29	169	C
		Boorea Street (NW)	0.74	48	126	D
		<b>Overall</b>	<b>0.76</b>	<b>33</b>	<b>234</b>	<b>C</b>
	PM	St Hilliers Road (S)	0.38	75	16	E
		Boorea Street (SE)	0.66	31	171	C
		St Hilliers Road (NE)	0.64	32	205	C
		Boorea Street (NW)	0.62	40	103	D
		<b>Overall</b>	<b>0.66</b>	<b>34</b>	<b>205</b>	<b>C</b>
Boorea Street/ Percy Street	AM	Percy Street (S)	0.02	11	1	B
		Boorea Street (SE)	0.01	7	0	A
		Boorea Street (NW)	0.00	0	0	A
	PM	Percy Street (S)	0.01	9	1	A
		Boorea Street (SE)	0.01	7	0	A
		Boorea Street (NW)	0.00	0	0	A

On the basis of the above assessment, it is clear that the intersection of St Hilliers Road/ Gelibolu Parade and Boorea Street/ Percy Street currently operate well with minimal to no queues and delays on all approaches.

The intersection of Boorea Street/ St Hilliers Road/ Rawson Street currently experiences some queuing and delays on the northeast, southeast and northwest legs during both the AM and PM peak periods.

During the PM Peak period, queuing at the Station Road/Rawson Street intersection (located northwest) extends back to the Boorea Street/St Hilliers Road/Rawson Street intersection, shown in Figure 2.9, which in turn affects the traffic efficiency and operation of this intersection. This mostly impacts traffic on the southeast and northeast legs of the Boorea Street/ St Hilliers Road/ Rawson Street intersection. As such, it should be recognised that this impact is as a result of the Station Road/ Rawson Street intersection and associated congestion, rather than the intersection operation itself.

Figure 2.9: Boorea Street/ St Hilliers Road/ Rawson Street Intersection Congestion due to Station Road/ Rawson Street Intersection located to the Northwest



## 2.4 Car Parking

### 2.4.1 Supply

GTA Consultants compiled an inventory of publicly available on-street car parking within approximately 200m of the subject site. The inventory identified a total of 246 unrestricted on-street spaces, with the breakdown presented below:

- Percy Street south of Boorea Street – 117 spaces
- Gelibolu Parade between St Hilliers Road and Percy Street – 20 spaces
- Gelibolu Parade between Dartbrook Road and St Hilliers Road – 79 spaces
- St Hilliers Road south of Boorea Street – 50 spaces.

### 2.4.2 Demand

Parking demand surveys were undertaken by GTA Consultants within the nominated area throughout a typical weekday (on 5 May 2017 at 7:00am, 7:30am, 8:00am, 8:30am and 9:00am as well as 3:00pm, 3:30pm, 4:00pm, 4:30pm and 5:00pm).

The peak results for AM and PM peak periods are summarised in Table 2.4 and Table 2.5 respectively.

**Table 2.4: Summary of AM Peak Public Parking Demand**

Location	Restrictions	Supply (No of spaces)	Peak Demand (Vehicles)					Minimum Vacancies*
			7:00am	7:30am	8:00am	8:30am	9:00am	
Percy Street south of Boorea Street	Unrestricted	117	18	22	30	33	35	82
Gelibolu Parade between St Hilliers Road and Percy Street		20	0	0	0	1	1	19
Gelibolu Parade between Dartbrook Road and St Hilliers Road		79	32	29	27	27	26	47
St Hilliers Road south of Boorea		50	49	46	44	40	38	1
<b>Total</b>		<b>266</b>	<b>99</b>	<b>97</b>	<b>101</b>	<b>101</b>	<b>100</b>	<b>149</b>

\* Peak demand for whole of study area

**Table 2.5: Summary of PM Peak Public Parking Demand**

Location	Restrictions	Supply (No of spaces)	Peak Demand (Vehicles)					Minimum Vacancies*
			3:00pm	3:30pm	4:00pm	4:30pm	5:00pm	
Percy Street south of Boorea Street	Unrestricted	117	37	34	36	36	35	80
Gelibolu Parade between St Hilliers Road and Percy Street		20	1	1	1	1	1	19
Gelibolu Parade between Dartbrook Road and St Hilliers Road		79	34	28	24	23	23	45
St Hilliers Road south of Boorea		50	31	27	30	33	30	17
<b>Total</b>		<b>266</b>	<b>103</b>	<b>90</b>	<b>91</b>	<b>93</b>	<b>89</b>	<b>161</b>

\* Peak demand for whole of study area

Table 2.4 and Table 2.5 indicate that public on-street car parking demands in the nominated area are relatively low, with AM and PM peak period demands respectively equal to an occupancy rate of 38% (149 vacancies) and 39% (161 vacancies) for parking in the vicinity of the site.

## 2.5 Public Transport

A review of the public transport available in the vicinity of the site is summarised in Table 2.6 and illustrated in Figure 2.10.

**Table 2.6: Public Transport Provision**

Service	Route #	Route Description	Location of Stop	Distance to Nearest Stop	Frequency On/Off Peak
Bus	908	Bankstown to South Granville and Merrylands	Auburn Road opposite Queen Street	950m Northwest	35 minutes peak / 1 hourly off peak
	909	Bankstown to Auburn and Parramatta			30 minutes peak and off peak
	911	Bankstown to Auburn			30 minutes peak / hourly off peak
	S3	Auburn to Chrisholm Road			2.5 hours off peak
Train	T1	North Shore, Northern and Western Line	Auburn Station	700m Northwest	6 minutes peak/ 30 minutes off peak
	T2	Airport, Inner West and South Line			
	T6	Carlingford Line			

**Figure 2.10: Public Transport Network Map**



Source: [http://www.transdevnsw.com.au/uploads/16447\\_Region\\_13\\_Network\\_Map\\_NOV16.pdf](http://www.transdevnsw.com.au/uploads/16447_Region_13_Network_Map_NOV16.pdf) (18 April 2017)

## 2.6 Pedestrian Infrastructure

Pedestrian paths are located along both sides of the majority of roads in the vicinity of the site. In addition, signalised pedestrian crossings are provided on all legs of the Boorea Road/ St Hilliers Road/ Rawson Street intersection except for the western leg across Rawson Street. The existing pedestrian infrastructure provides a convenient link between the site and Auburn Town Centre (including Auburn railway station).

## 2.7 Cycle Infrastructure

There exists a well-developed network of cycling facilities in the vicinity of the site, as illustrated the Auburn bicycle route map presented Figure 2.11.

Figure 2.11: Extract of the Auburn Bicycle Route Map

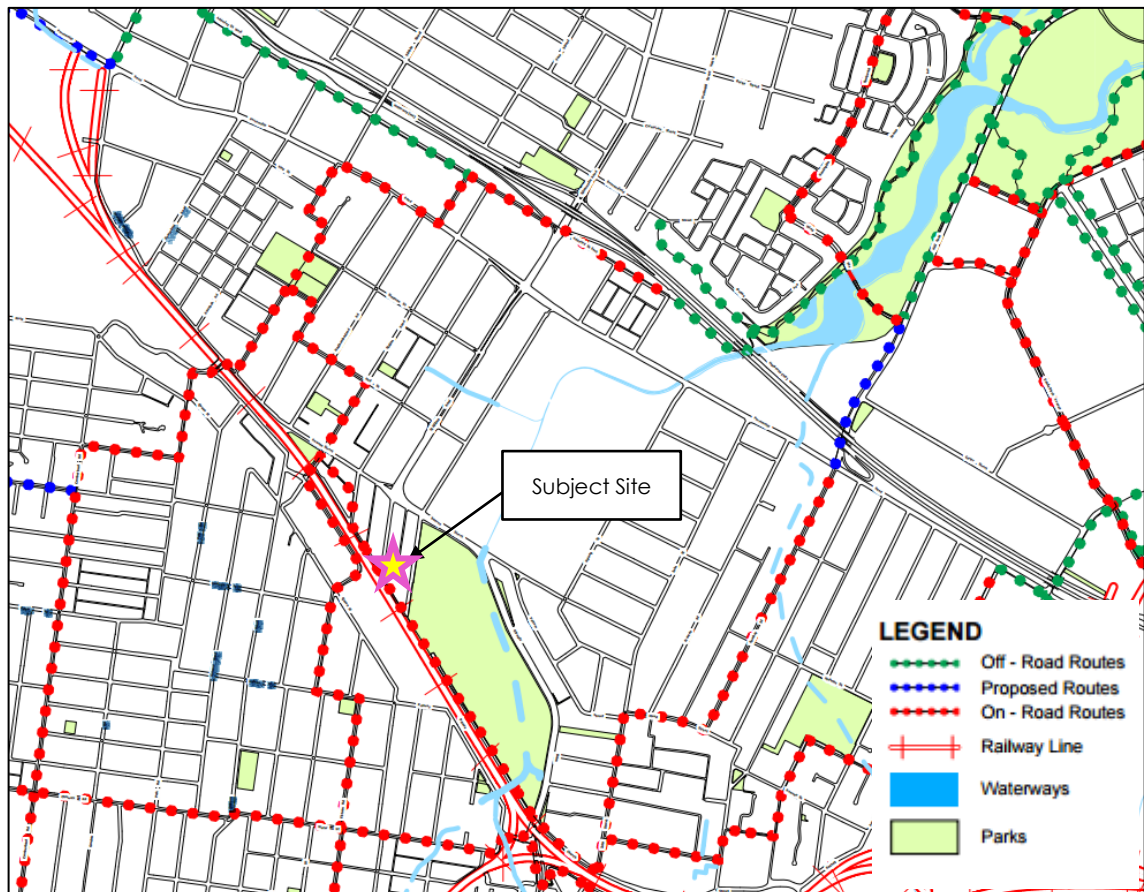

Source: <http://www.auburn.nsw.gov.au/Explore/Transport/TransportDocuments/Cycle%20Routes.pdf> (18 April 2017)

Based on the Auburn bicycle route map, on-road bicycle lanes are located along Gelibolu Parade, through the southern edge of the Ashfield field and Church Street. These bike paths provide connectivity to off-road cycle route along the M4 Western Motorway to the north and the suburb of Lidcombe to the south.



## 3. Development Proposal

### 3.1 Land Uses

The Planning Proposal seeks to allow additional permitted uses for the site, including kindergarten, primary school, secondary school and administration office uses, which are currently prohibited under the current Light Industrial Zone (IN2).

The indicative schedule for the conceptual scheme is summarised in Table 3.1.

**Table 3.1: Indicative Schedule**

Use	Description	Size	
		Staff	Student
Educational	Kindergarten	2	50
	Primary School	19	300
	Secondary School	21	300
	Administration Office	8	-
<b>Total</b>		<b>50</b>	<b>650</b>

Source: Proposed school program by Architecture Design Studio, dated 09 May 2017 (See Appendix C)

### 3.2 Mode Choice

Due to the non-governmental nature and location of the proposed school, it is noted that the school's catchment would primarily be within the Auburn LGA with some enrolments from the Greater Western Sydney region of NSW.

The proposed development would be serviced by public transportation including bus and train services, located within 950 metres and 700 metres radius from the Auburn Road opposite Queen Street bus stop and Auburn Railway Station respectively. To reduce the usage of cars, it is proposed that dedicated school bus services be used to cater for students from the nearby communities.

Based on the above, it is expected that 30 percent of students from the catchment areas would travel to the proposed school by car either as a driver (5 percent) or a passenger (25 percent). School bus and train services are expected to make up 40 percent and 20 percent of total commuter travel modes respectively.

Considering the existing established walking and cycling environment, a small percentage (10 percent) of the students is expected to either walk or cycle to the proposed school from the adjacent residential neighbourhoods.

### 3.3 Vehicle Access

Vehicular access is proposed at the same location of the existing crossover to St Hilliers Road along the western boundary in the north-west corner of the site. It is proposed that the access allows for only left-in and left-out movements to reduce vehicular conflicts at the intersection of St Hilliers Road/ Gelibolu Parade. This restriction is considered the most appropriate given the close proximity of the access to the intersection.

Due to the movement restrictions at the access along St. Hilliers Road, any opportunity to incorporate an additional two-way vehicular access along Gelibolu Parade would be investigated during detailed design, along with appropriate entry geometry that facilitates a suitable vehicle entry and exit speeds, without compromising pedestrian and cyclist safety.

### 3.4 Car Parking

On-site car parking is to be provided for use by staff, students and visitors. Further detail on the car parking requirements in accordance with the DCP 2010 for the proposed development is provided in Section 3.4 of this report.

### 3.5 Loading Areas

It is proposed that garbage collection would continue to occur on-street along the site's western frontage on St Hilliers Road, with bins to be wheeled to the St Hilliers Road kerbside for collection.

All loading activities related to deliveries, courier activity, maintenance etc. are proposed to be carried out at the proposed pick-up / drop-off zone west of the building outside of the school's peak hours. The pick-up / drop-off zone is proposed for use of service vehicles up to 10.5m long medium rigid vehicles.

### 3.6 Pick-up/ Drop-off

The proposal would include a pick-up / drop-off zone west of the building.

Given the low utilisation of the existing car parking area for the Cumberland Council Athletic Field during the school peak hours, there is an opportunity to use the parking facility to cater for a demand spillover for pick-up / drop-off activities.

Based on an average bus capacity of 60 passengers and 60 percent occupancy, with 600 primary and secondary students, it is expected that a maximum of six to seven buses would arrive and depart before and after the school operation hours. There is also an opportunity to provide a bus zone for pick-up / drop-off activities on the western edge of Percy Street along the property boundary.

The above opportunities would be investigated during development application (DA) stage.

Figure 3.1: Pick-up/ Drop-off Opportunities



Basemap: Nearmap

## 4. Car Parking

### 4.1 Car Parking Requirements

The parking provision objectives detailed in the Cumberland Council 'Parking and Loading' DCP 2010 are reproduced below:

- "a. To promote greater bicycle use, decrease the reliance on private vehicles and encourage alternative, more sustainable modes of transport.*
- b. To provide convenient and safe access and parking to meet the needs of all residents and visitors.*
- c. To provide access arrangements which do not impact upon the efficient or safe operation of the surrounding road system.*
- d. To encourage the integrated design of access and parking facilities to minimise visual and environmental impacts"*

The car parking requirements for different development types are set out in Cumberland Council's 'Parking and Loading' DCP 2010. DCP 2010 does not specify a parking rate for kindergarten. As such, the car parking rate for child care use has been applied for kindergarten use. A review of the car parking rates and the floor area schedule results in a parking requirement for the proposed development is summarised in Table 4.1.

**Table 4.1: DCP 2010 Car Parking Requirements**

Land Use	Size		DCP Parking Rate	DCP Parking Requirement	
	Staff	Child/ Student		Staff	Child/ Student
Kindergarten	2	50	1 space per 4 children + drop-off pick-up facility	13	drop-off pick-up facility
Primary School	19	300	1 space per 2 staff	10	-
Secondary School	21	300 (including 50 year 12 students)	1 space per 20 year 12 students + 1 space per 2 staff	11	3
Administration Office	8	-	1 space per 2 staff	4	
Subtotal				<b>38</b>	<b>3 + drop-off pick-up facility</b>
Visitor	10% of overall parking			<b>4</b>	
<b>Total</b>				<b>45 + drop-off pick-up facility</b>	

Based on the above, the proposal would generate a requirement to provide 45 car spaces and a drop-off/ pick-up facility.

## 4.2 Empirical Assessment of Car Parking Demand

Guide to Traffic Generating Developments (RMS, 2002) does not have car parking rate for kindergarten use. As such, reference has been made to the Guide (2002) and the GTA database to determine the likely car parking requirements of the child care centre use.

### **RMS Guide**

The RMS Guide recommends that child care centre car parking be provided at a rate of 1 space per 4 children. This rate includes staff parking requirements as well as pick-up/ drop-off spaces for parents. The Guide continues to state that "*consideration could be given to reducing parking required if convenient and safe on-street parking is available (e.g. indented parking bays), provided that the use of such parking does not adversely affect the amenity of the adjacent area.*"

### **GTA Database**

The GTA database includes car parking survey results of 18 child care centres. The data indicates the following peak hour car parking demands:

- Average: 0.19 spaces per child
- 85<sup>th</sup> Percentile: 0.26 spaces per child

This rate includes staff parking requirements as well as pick-up/ drop-off spaces for parents/ carers.

### **Summary**

Application of the above rates (conservatively using 0.26 spaces per child) indicates a peak car parking demand of 13 spaces for the child care centre use, incorporating staff and pick up/ drop off spaces.

Based on the above, the proposal would generate a requirement to provide 45 car spaces (including drop-off/ pick-up facility).

## 5. Sustainable Transport Infrastructure

### 5.1 Bicycle Parking Requirements

The *NSW Planning Guidelines for Walking and Cycling* (Department of Infrastructure, Planning and Natural Resources, 2004) aims to assist land use planners and related professionals to improve consideration of walking and cycling in their work. The guidelines have been designed to provide a walking and cycling focus to the NSW Government's *Integrating Land Use & Transport Planning* policy package. The *Planning Guidelines for Walking and Cycling* contains suggested bicycle parking provision rates for different land use types.

On the above basis, the suggested bicycle parking provision for the development is summarised in Table 5.1.

**Table 5.1: Recommended Bicycle Parking Rates**

Land Use	Size		Bicycle Parking Rate		Bicycle Parking Provision	
	Staff	Student	Staff	Student/Visitors	Staff	Student/Visitors
Kindergarten	2	50	3% to 5%	5% to 10%	1	2-5
Primary and High Schools & Administration Office	48	600			2-3	30-60
<b>Total</b>					3-4	32-65
					<b>35 to 69 spaces</b>	

It is therefore recommended that the above bicycle provisions of between 35 and 69 be provided, with such details to be shown on detailed design plans to be prepared as part of any future development application for the site.

### 5.2 Pedestrian and Bicycle Facilities

The proposal would incorporate primary pedestrian access points along all frontages to Percy Street, Gelibolu Parade and St Hilliers Road. Improvements to existing pedestrian and bicycle facilities should include line marking, bike/ pedestrian crossings, signage and where appropriate speed humps.

The exit point of site access requires the following safety devices to be installed within the boundary of the property:

- Stop signs
- A white, unbroken line at the exit point appropriate to accompany stop signs
- Two fish eye mirrors to improve sighting of pedestrians/ bikes traversing the shared public path area
- A speed hump within eight metres of the exit point
- Speed limit of 10 km per hour to be enforced within the property
- Speed limit of 40 km per hour to be enforced outside the property along Percy Street, Gelibolu Parade and St Hilliers Road; which should be clearly sign posted.

Figure 5.1 shows the proposed infrastructure treatments to be carried out to meet a priority route standard and improve safety for cyclists and pedestrians in the vicinity of the site. These treatments can be included as part of the Council's broader New Auburn Bike Plan initiatives with the supports by Australian Turkish Maarif Foundation.

**Figure 5.1: Proposed Infrastructure Treatments for Cycle and Pedestrians**



Basemap source: Nearmap

### 5.3 Public Transport

The site is located within 900m of existing public transport stops and services. The design development of the proposal is to be mindful of the proximity to these public transport stops and incorporate design elements to ensure direct, safe and efficient pedestrian access.

## 6. Traffic Impact Assessment

### 6.1 Traffic Generation

The proposed development is a traffic generating development per Schedule 3 of State Environmental Planning Policy (Infrastructure) 2007 (SEPP, 2007) under the category "educational establishments" with "50 or more students".

No specific traffic generation rate is provided in the RMS Guide for kindergarten, primary and secondary education uses. As such, in order to estimate the anticipated traffic generation of the proposed education facility, a first principles based assessment has been undertaken.

The proposed education facility generates a DCP 2010 requirement to provide 38 car parking spaces on-site for staff. It has been conservatively assumed that each of these 38 spaces would generate one vehicle trips in the AM and PM school peak hours, representing staff arriving to and departing from the proposed school. The staff would typically arrive before the students' arrivals and depart after the students' departures. As such, it is assumed only 10 percent of the vehicle trips, which are equivalent to four trips per hour would occur during the school's AM and PM peak periods.

As discussed, given that five percent of the 650 students would drive and 25 percent would be dropped off and picked up, the proposal could generate the following during the AM and PM school's peak period:

- 5 percent as driver: 33 vehicle trips per hour
- 25 percent as passenger: 325 vehicle trips per hour

Based on the above and the anticipated 14 vehicle trips per hour for school buses and four vehicle trips per hour for staff, the proposal is expected to generate a total of 376 vehicle trips per hour during any peak periods.

It is noted that the above assessment makes no account of existing traffic generation of the land uses within the development site and is therefore considered a conservative approach.

### 6.2 Distribution and Assignment

The directional distribution and assignment of traffic generated by the proposal will be influenced by a number of factors, including the:

- i configuration of the arterial road network in the immediate vicinity of the site
- ii existing operation of intersections providing access between the local and arterial road network
- iii surrounding employment centres, retail centres and schools in relation to the site
- iv configuration of access points to the site.



It is noted that the turn restrictions from Rawson Street to St Hilliers Road and Boorea Street to Percy Street on arrival to the site as well as from Percy Street to Boorea Street on departure from the site will impact the distribution and assignment of traffic entering and exiting the site.

Traffic accessing the site from the north will use St Hilliers Road. Traffic accessing the site from the west would be dispersed across the adjacent streets (i.e. Station Road, Gelibolu Parade and Dartbrook Road) so as to be able to approach the site from the west to enter the proposed driveway along Gelibolu Parade and pick-up/ drop-off area along Percy Street. Traffic from the east will largely enter from Percy Street with buses entering from Dartbrook Road. The arrival routes are illustrated in Figure 6.3.

**Figure 6.1: Proposed Infrastructure Treatments for Cycle and Pedestrians**



Basemap source: Google Maps

Likewise, traffic departing the site towards the north will utilise St Hilliers Road and Percy Street towards Boorea Street. Traffic departing towards the west would be dispersed across Dartbrook Street, St Hilliers Road and Percy Street while traffic departing towards the east will use St Hilliers Road. All buses would depart from the site via Percy Street towards Boorea Street. The departure routes are illustrated in Figure 6.2.

Figure 6.2: Proposed Infrastructure Treatments for Cycle and Pedestrians



Basemap source: Google Maps

Having consideration for the above and for the purposes of estimating vehicle trips, the assumed directional distributions are shown in Figure 6.3 with Figure 6.4 prepared to show the estimated turning movements in the vicinity of the site following full development.

The directional splits of traffic (i.e. the ratio between the inbound and outbound traffic movements) have been assumed as follows:

- AM Peak Period
  - Drivers 100% in/ 0% out
  - Bus/ Passengers 50% in/ 50% out
- PM Peak Period
  - Drivers 0% in/ 100% out
  - Bus/ Passengers 50% in/ 50% out

Figure 6.3: Arrival and Departure Distribution of Traffic

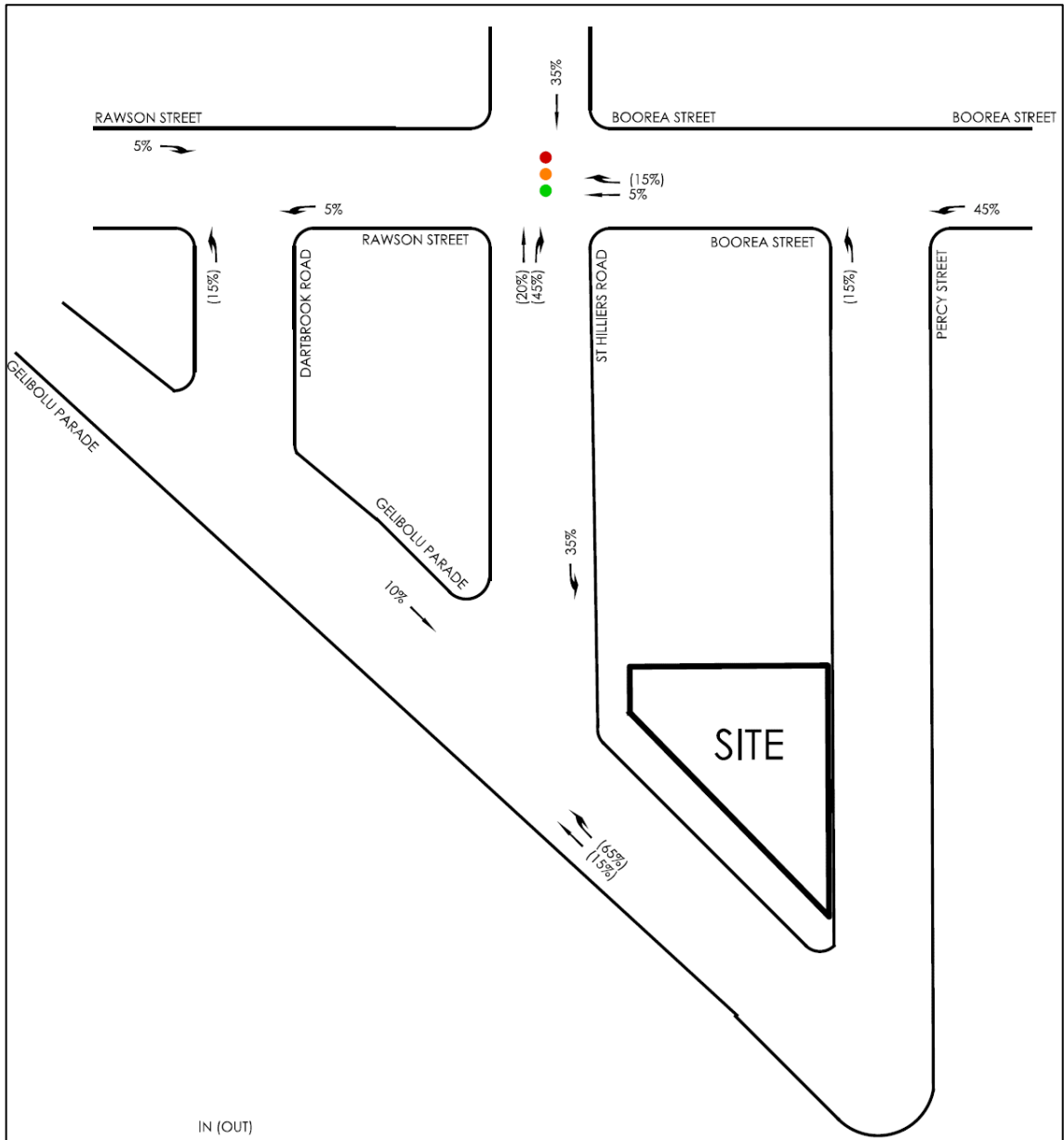
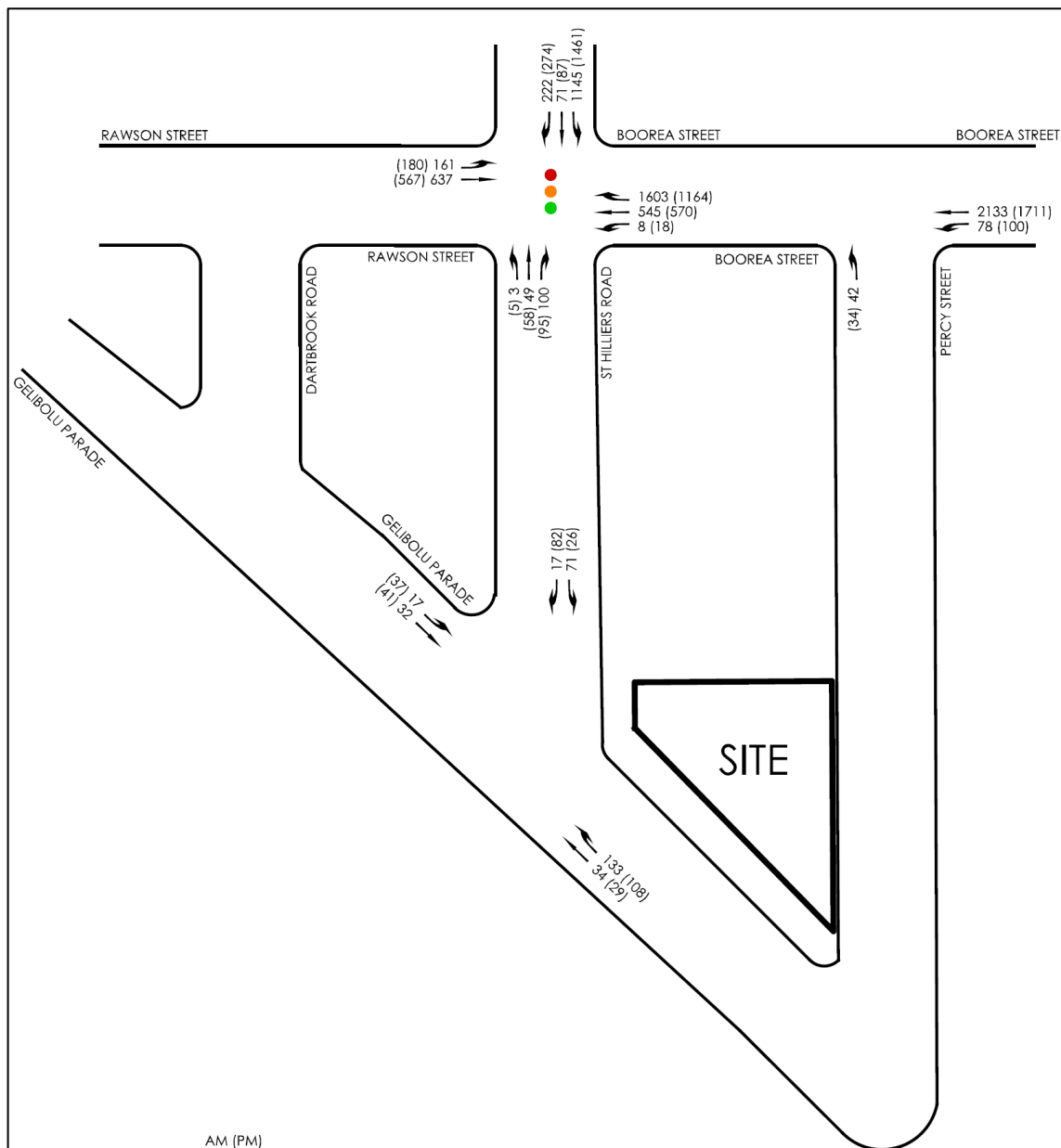

Figure 6.4: Weekday AM and PM Peak Hour Traffic Volumes plus Development Traffic



### 6.3 Traffic Impact

Overall, the key intersection of Boorea Road/ St Hilliers Road/ Rawson Street will continue to operate within capacity, with moderate impacts to the existing road network. The intersections of St Hilliers Road/ Gelibolu Parade and Boorea Street/ Percy Street are expected to operate well under their capacities.

Moreover, the use of Percy Street, Gellibolu Parade and St Hilliers Road by vehicles accessing educational uses which abut them is entirely appropriate and consistent with their functional roles in the road network.

Table 6.1 presents a summary of the expected future operation of the nominated intersections, with full results included in Appendix B.

**Table 6.1: Future Operating Conditions**

Intersection	Peak	Leg	Degree of Saturation (DOS)	Average Delay (sec)	95th Percentile Queue (m)	Level of Service (LOS)
St Hilliers Road/ Gelibolu Parade	AM	Gelibolu Parade (SE)	0.11	5	4	A
		St Hilliers Road (N)	0.02	7	1	A
		Gelibolu Parade (NW)	0.04	7	0	A
	PM	Gelibolu Parade (SE)	0.09	5	3	A
		St Hilliers Road (N)	0.03	7	1	A
		Gelibolu Parade (NW)	0.05	7	0	A
Boorea Road/ St Hilliers Road/ Rawson Street	AM	St Hilliers Road (S)	0.83	72	51	E
		Boorea Street (SE)	0.83	36	272	D
		St Hilliers Road (NE)	0.74	34	183	C
		Boorea Street (NW)	0.83	56	134	E
		<b>Overall</b>	<b>0.83</b>	<b>40</b>	<b>272</b>	<b>D</b>
	PM	St Hilliers Road (S)	0.72	67	46	E
		Boorea Street (SE)	0.74	36	187	D
		St Hilliers Road (NE)	0.73	37	247	D
		Boorea Street (NW)	0.68	43	103	D
		<b>Overall</b>	<b>0.74</b>	<b>38</b>	<b>247</b>	<b>D</b>
Boorea Street/ Percy Street	AM	Percy Street (S)	0.11	12	3	B
		Boorea Street (SE)	0.06	7	0	A
		Boorea Street (NW)	0.00	0	0	A
	PM	Percy Street (S)	0.07	10	2	A
		Boorea Street (SE)	0.07	7	0	A
		Boorea Street (NW)	0.00	0	0	A

## 6.4 Other Developments Traffic

As discussed, a detailed traffic model and SIDRA assessments of several key intersections within the Auburn LGA have been carried out by Hyder Consulting (2012). It is to be noted the report states the closure of St Hilliers Road southern approach will negatively impact the accessibility of the residents and visitors to the Auburn Gallipoli Mosque. It is also concluded in the report that the closure will require a detailed accessibility and impact assessment. Further, a review of the RMS AADT data show that the peak hours along Olympic Drive (near Percy Street) occurs between 7am to 8am and 4.30pm to 5.30pm during AM and PM peak periods respectively.

It is also understood from Jacobs (2015) Traffic Impact Assessment Report for the proposed 3-storey residential aged care facility adjacent of the subject site, the peak traffic generation will occur between 2pm and 3pm during a shift changeover.

Based on the above, against existing and future traffic volumes near the site, the additional traffic generated by the proposed development could not be expected to compromise the safety or function of the surrounding road network. This is due to the fact that the school's AM and PM peak hours of 8am to 9am and 3pm to 4pm respectively, will not coincide with the commuter peak hours at the intersection of key intersections within Auburn LGA as well as the peak hour of adjacent site.

## 6.5 Friday Prayer Traffic

It is understood that Auburn Gallipoli Mosque holds a congregational prayer every Friday from approximately 12pm to 1.30pm. The traffic associated to the Friday prayer session will arrive in between 11am and depart by 2pm, which will occur outside the school's peak hours.

It is recommended to implement three-hour car parking restrictions (11am to 2pm, Friday only) with associated signage of the parking spaces along Gelibolu Parade. The proposed car parking restrictions are to support the existing parking demand due to Friday prayer by ensuring that parking adjacent to the Auburn Gallipoli Mosque is available during Friday noon periods for the visitors along Gelibolu Parade.

## 7. Conclusion

---

Based on the analysis and discussions presented within this report, the following conclusions are made:

- i The Planning Proposal seeks to allow additional permitted uses for the site, including kindergarten, primary school, secondary school and administration office uses, which are currently prohibited under the current Light Industrial Zone (IN2).
- ii Based on DCP 2010 and empirical assessment of car parking demand, the proposal would generate a requirement to provide 45 car spaces (including drop-off/ pick-up facility).
- iii It is recommended that the above bicycle provisions between 35 and 69 be provided and shown on detailed plans to be prepared as part of any future development application for the site.
- iv The proposal is anticipated to generate a total of 376 vehicle trips per hour during any peak periods.
- v There is adequate capacity in the surrounding road network to cater for the traffic generated by the proposal.
- vi The impacts of traffic generated by the proposal are not expected to compromise the safety or function of the road network.

# Appendix A

---

## Survey Results



Job No. : N3188  
 Client : GTA  
 Suburb : Boorea Street  
 Location : 2. Boorea St / Percy St

Day/Date : Tuesday, 2nd May 2017  
 Weather : Fine  
 Description : Classified Intersection Count  
 : Intersection Diagram



Hour Starting: 8:00  
 Vehicle Type: Lights

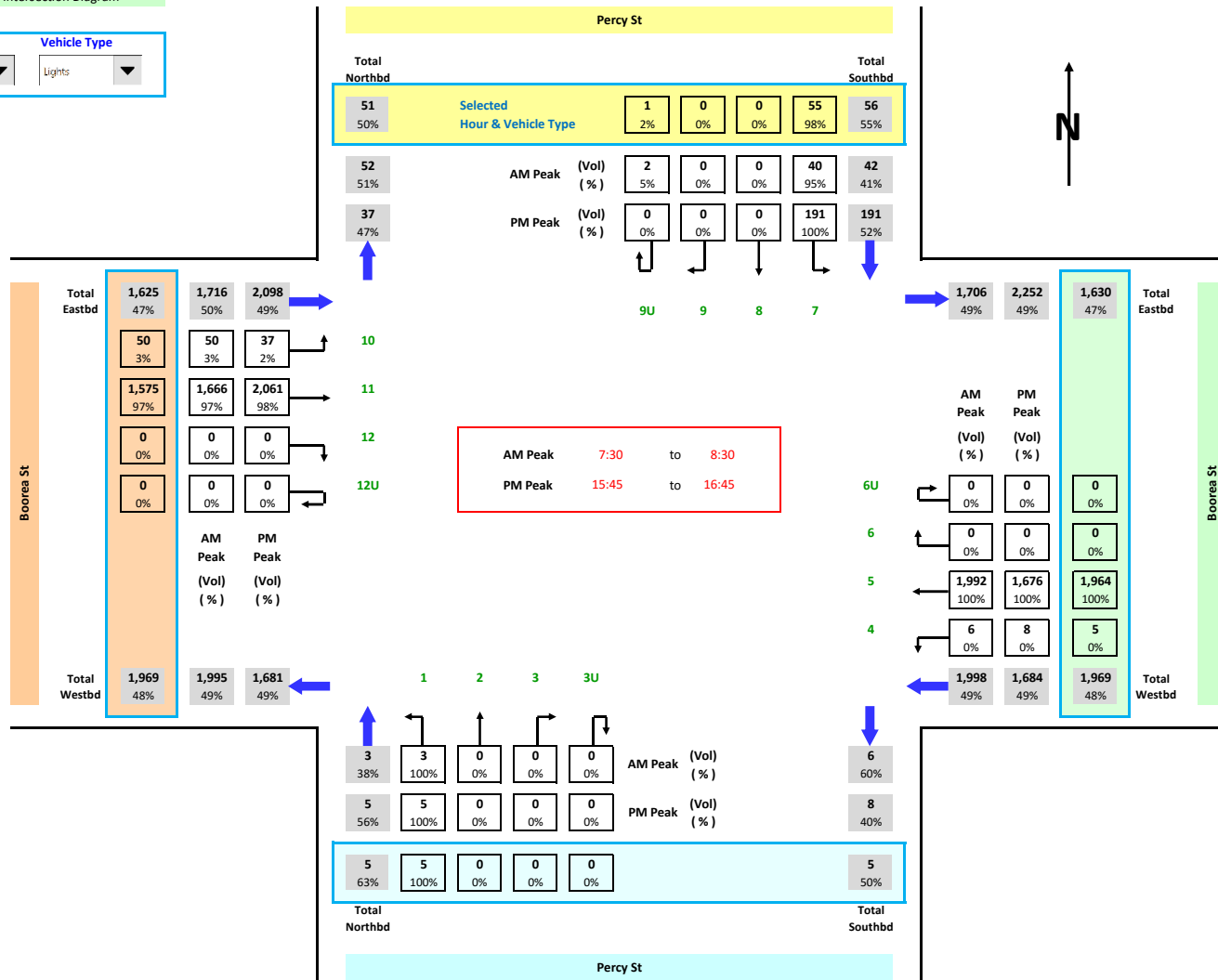



Job No. : N3188  
 Client : GTA  
 Suburb : Boorea Street  
 Location : 2. Boorea St / Percy St

Day/Date : Tuesday, 2nd May 2017  
 Weather : Fine  
 Description : Classified Intersection Count  
 : Intersection Diagram



Hour Starting: 8:00  
 Vehicle Type: All Vehicles

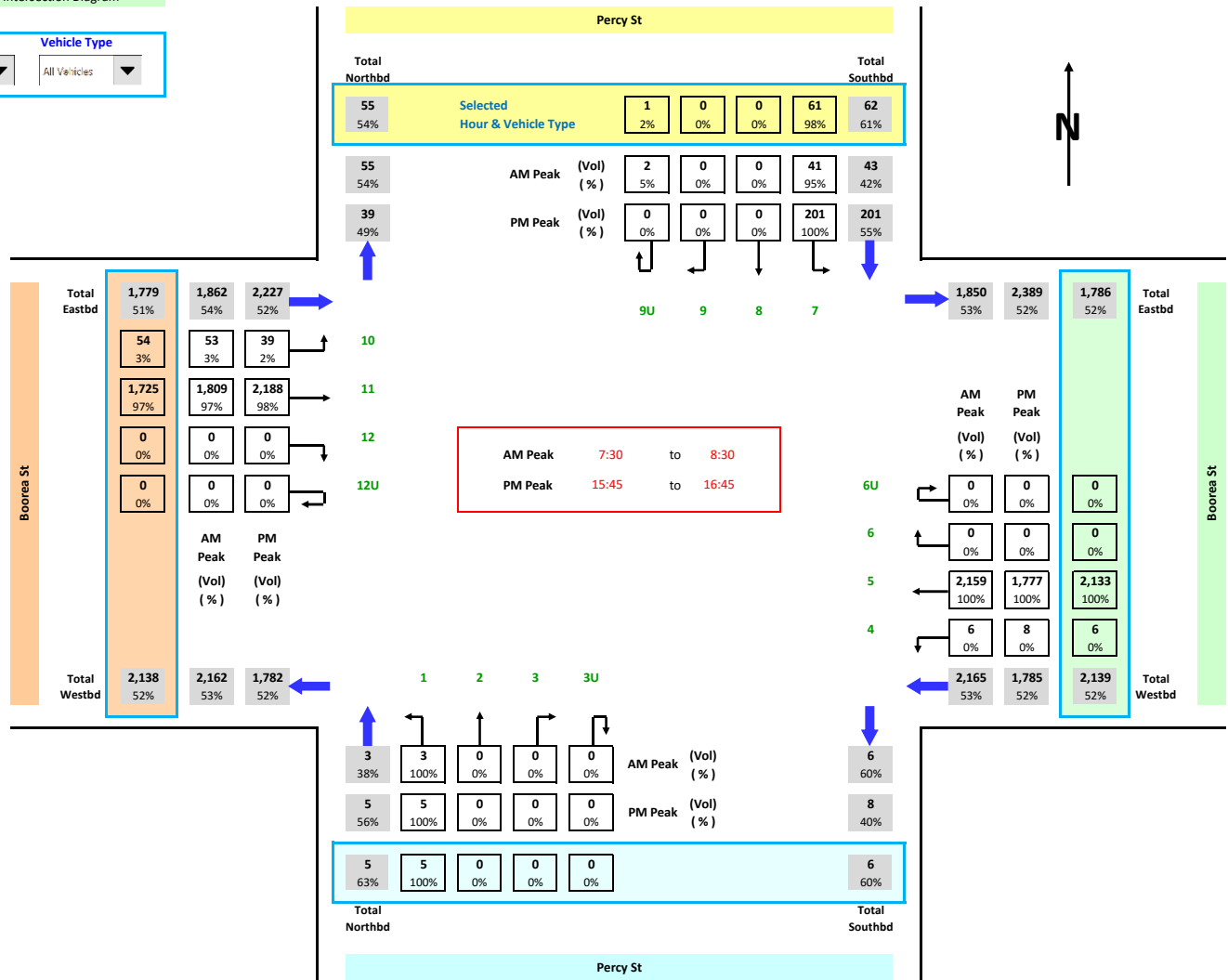

Job No. : N3188  
 Client : GTA  
 Suburb : Boorea Street  
 Location : 2. Boorea St / Percy St

Day/Date : Tuesday, 2nd May 2017  
 Weather : Fine  
 Description : Classified Intersection Count  
 : Intersection Diagram



Hour Starting : 5:00  
 Vehicle Type : Lights

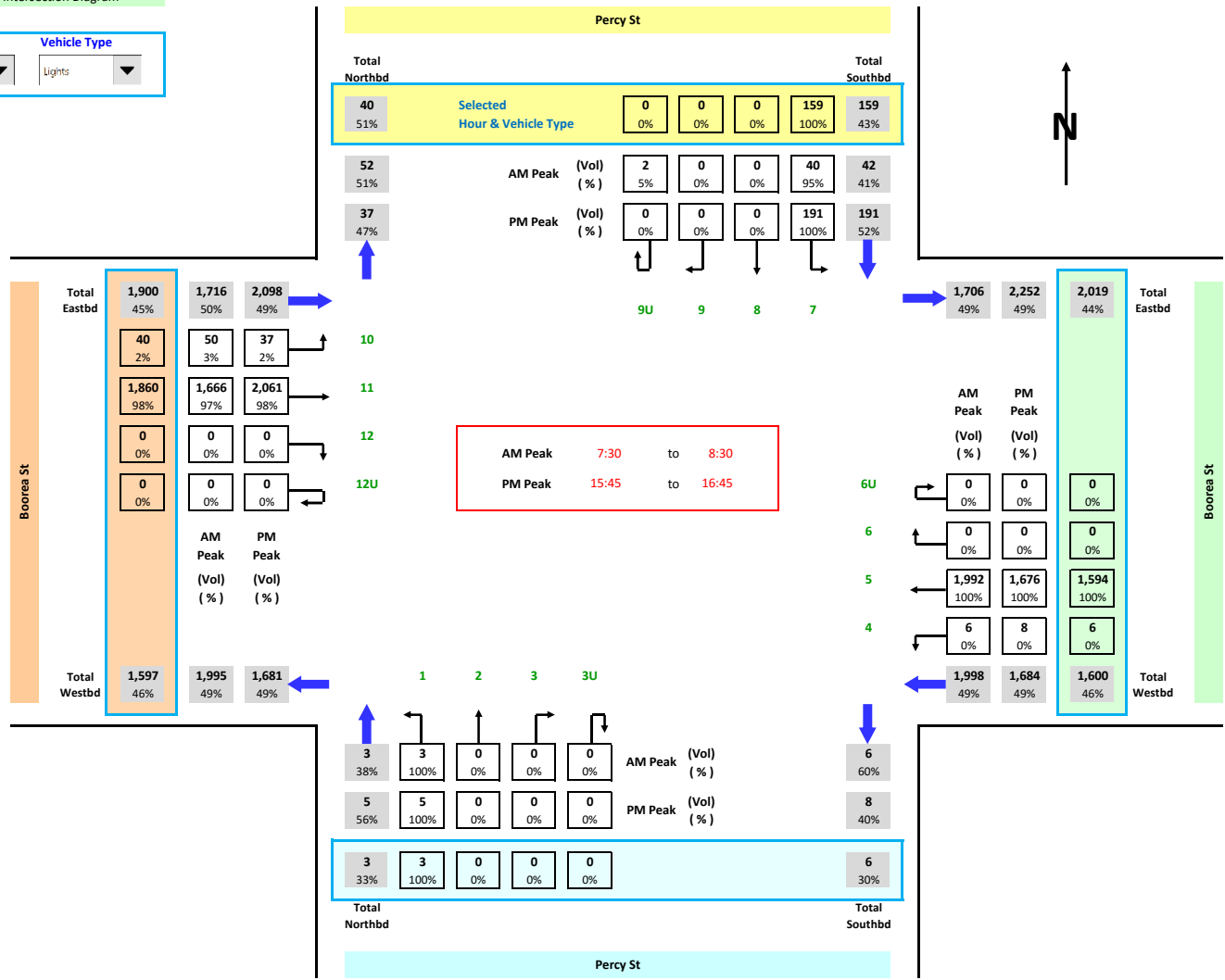

Job No. : N3188  
 Client : GTA  
 Suburb : Boorea Street  
 Location : 2. Boorea St / Percy St

Day/Date : Tuesday, 2nd May 2017  
 Weather : Fine  
 Description : Classified Intersection Count  
 : Intersection Diagram



Hour Starting: 5:00  
 Vehicle Type: Services

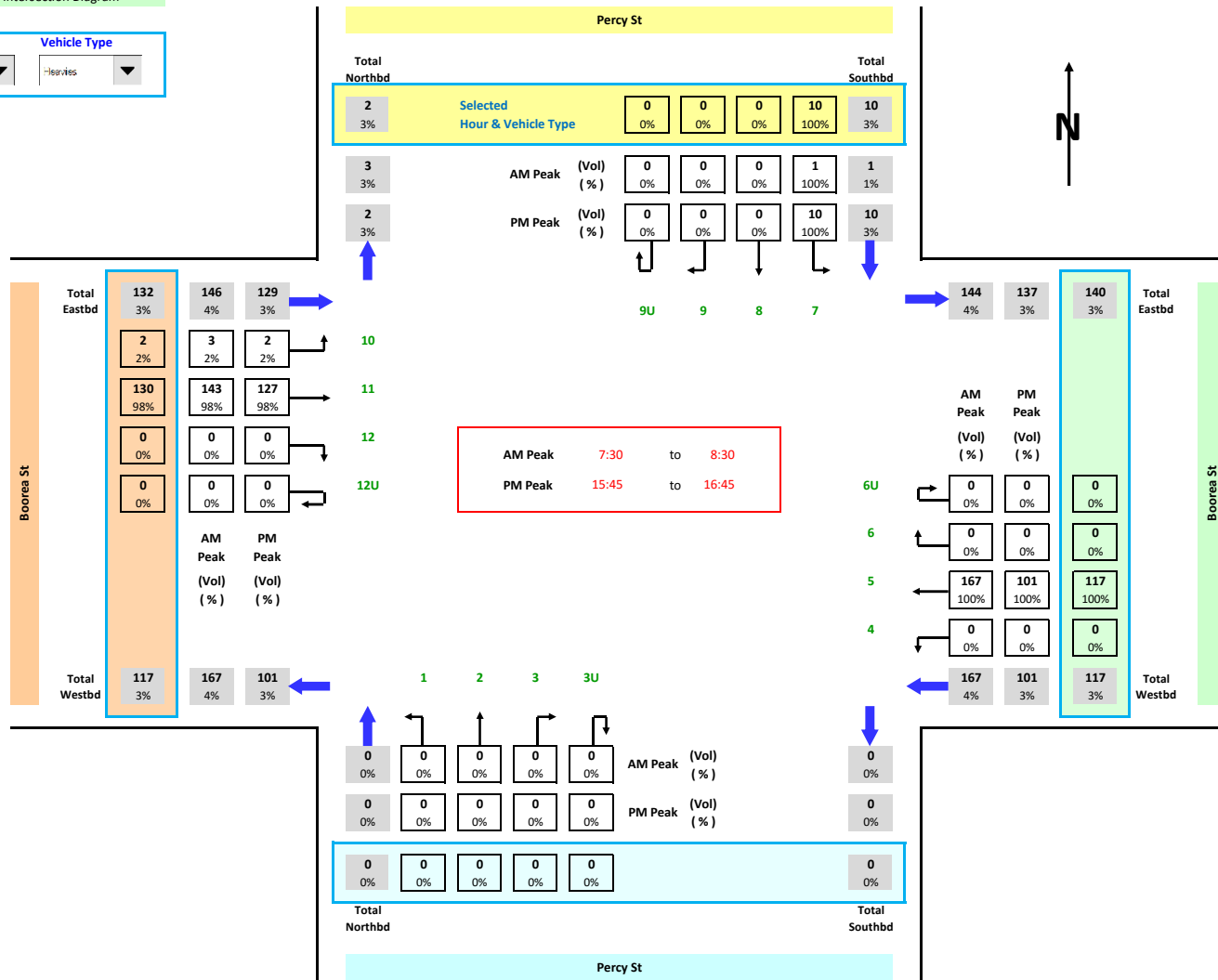

Job No. : N3188  
 Client : GTA  
 Suburb : Boorea Street  
 Location : 2. Boorea St / Percy St

Day/Date : Tuesday, 2nd May 2017  
 Weather : Fine  
 Description : Classified Intersection Count  
 : Intersection Diagram



Hour Starting : 5:00  
 Vehicle Type : All Vehicles

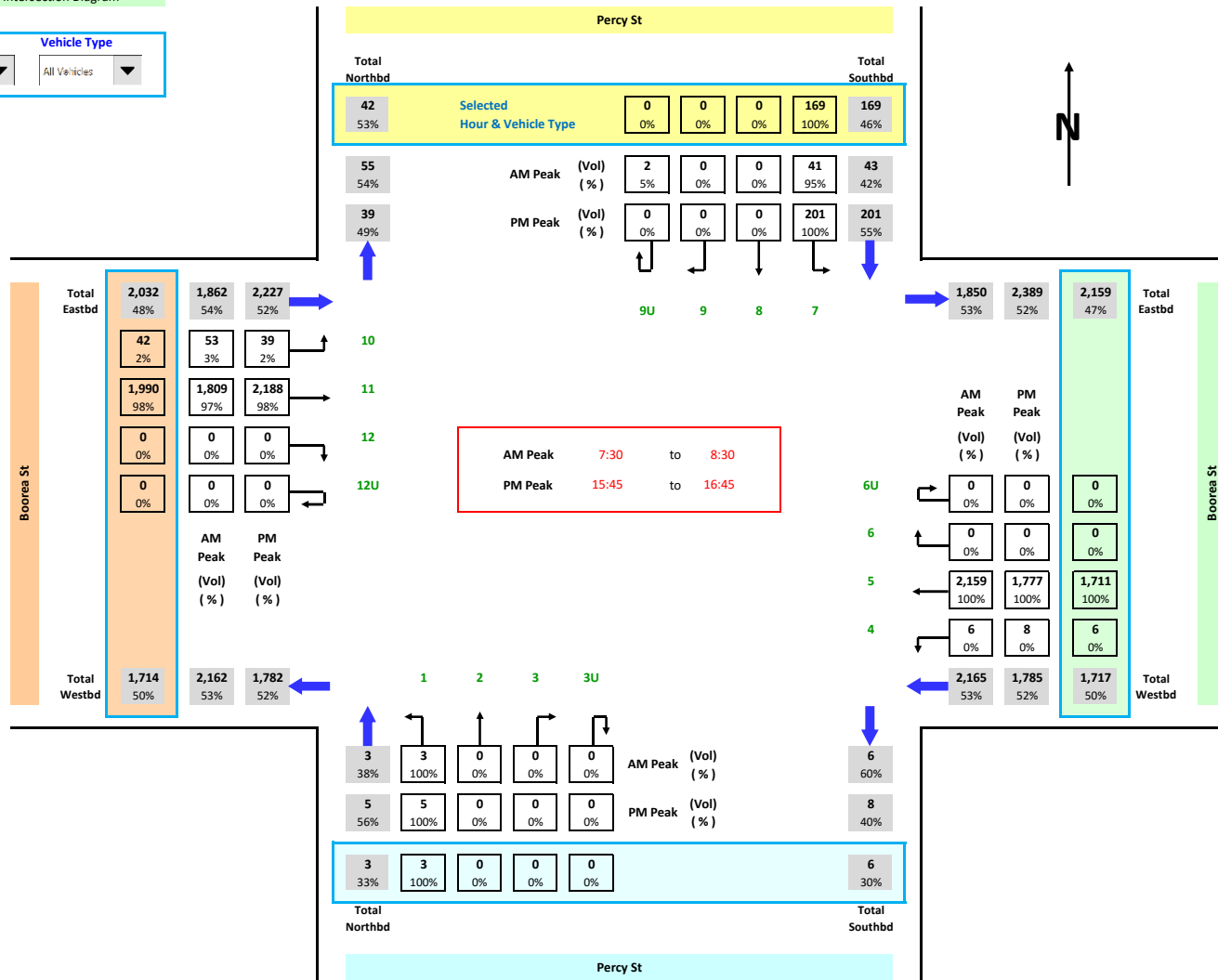

**Job No.** : N3188  
**Client** : GTA  
**Suburb** : Boorea Street  
**Location** : 1. St Hilliers Rd / Boorea St / Rawson St

**Day/Date** : Tuesday, 2nd May 2017  
**Weather** : Fine  
**Description** : Classified Intersection Count  
 : Intersection Diagram



**Hour Starting** : 8:00  
**Vehicle Type** : Lights

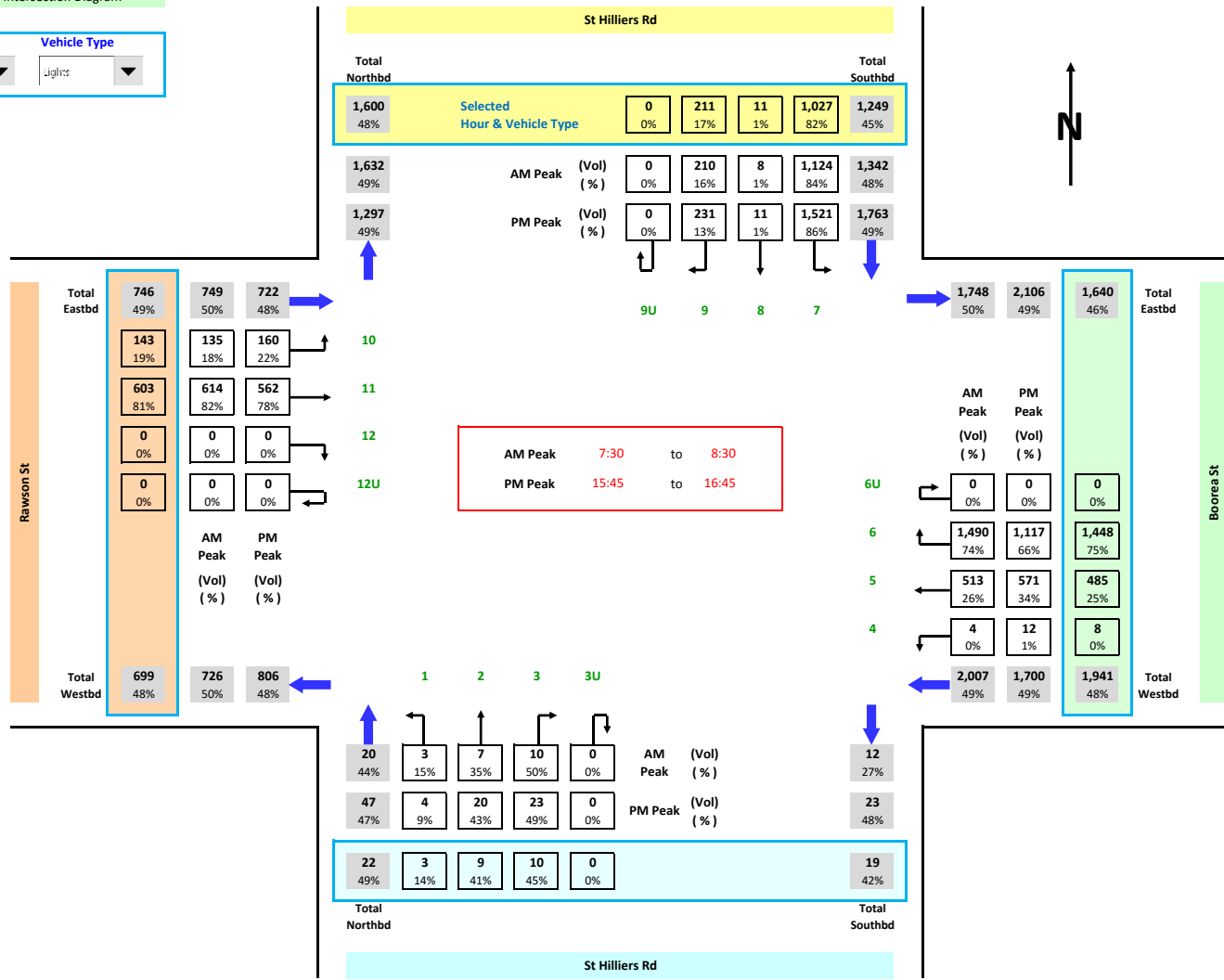

**Job No.** : N3188  
**Client** : GTA  
**Suburb** : Boorea Street  
**Location** : 1. St Hilliers Rd / Boorea St / Rawson St

**Day/Date** : Tuesday, 2nd May 2017  
**Weather** : Fine  
**Description** : Classified Intersection Count  
 : Intersection Diagram



**Hour Starting** : 8:00  
**Vehicle Type** : Heavies

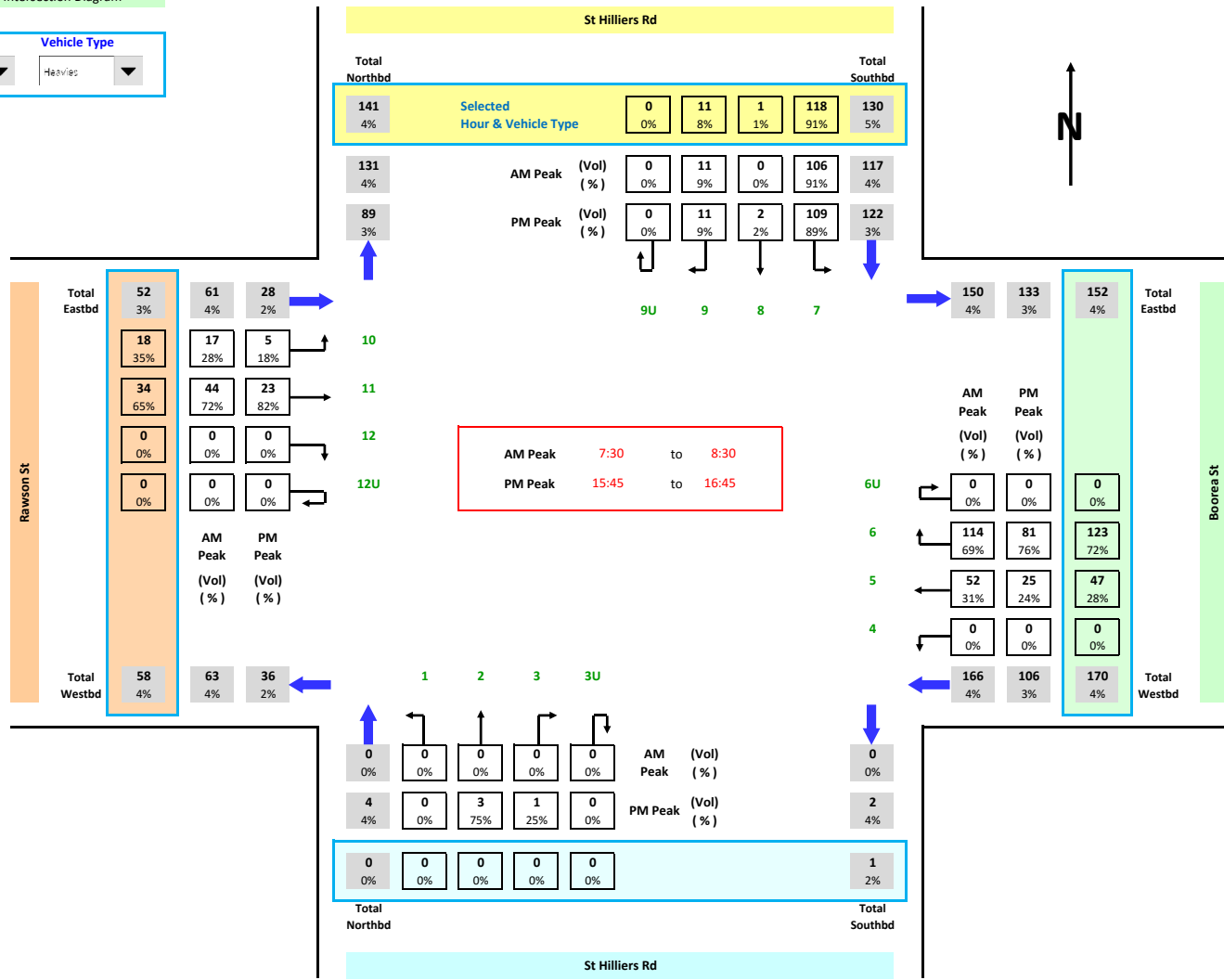



**Job No.** : N3188  
**Client** : GTA  
**Suburb** : Boorea Street  
**Location** : 1. St Hilliers Rd / Boorea St / Rawson St

**Day/Date** : Tuesday, 2nd May 2017  
**Weather** : Fine  
**Description** : Classified Intersection Count  
 : Intersection Diagram



**Hour Starting** : 8:00  
**Vehicle Type** : All Vehicles

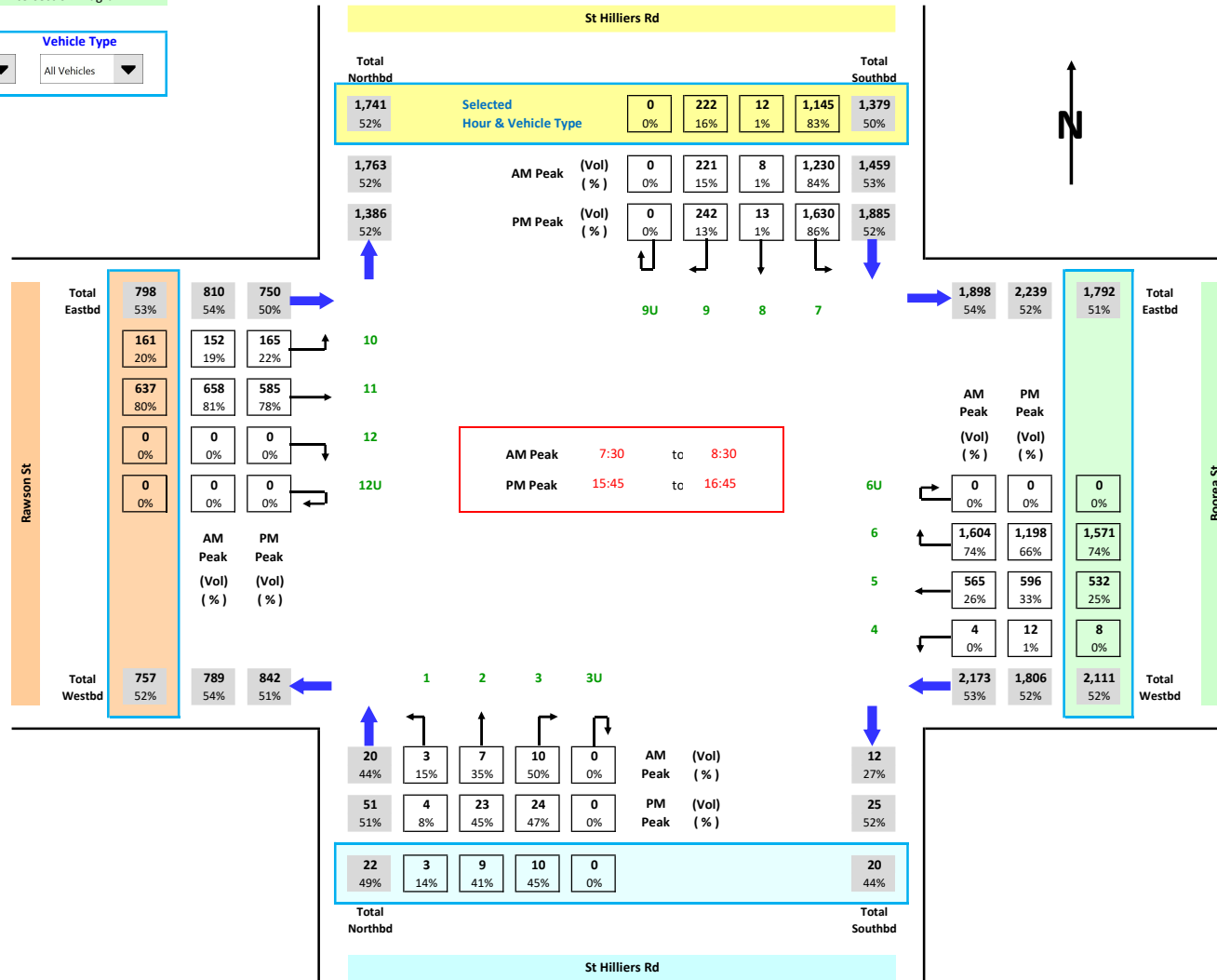

**Job No.** : N3188  
**Client** : GTA  
**Suburb** : Boorea Street  
**Location** : 1. St Hilliers Rd / Boorea St / Rawson St

**Day/Date** : Tuesday, 2nd May 2017  
**Weather** : Fine  
**Description** : Classified Intersection Count  
 : Intersection Diagram



**Hour Starting** : 15:00  
**Vehicle Type** : Lights

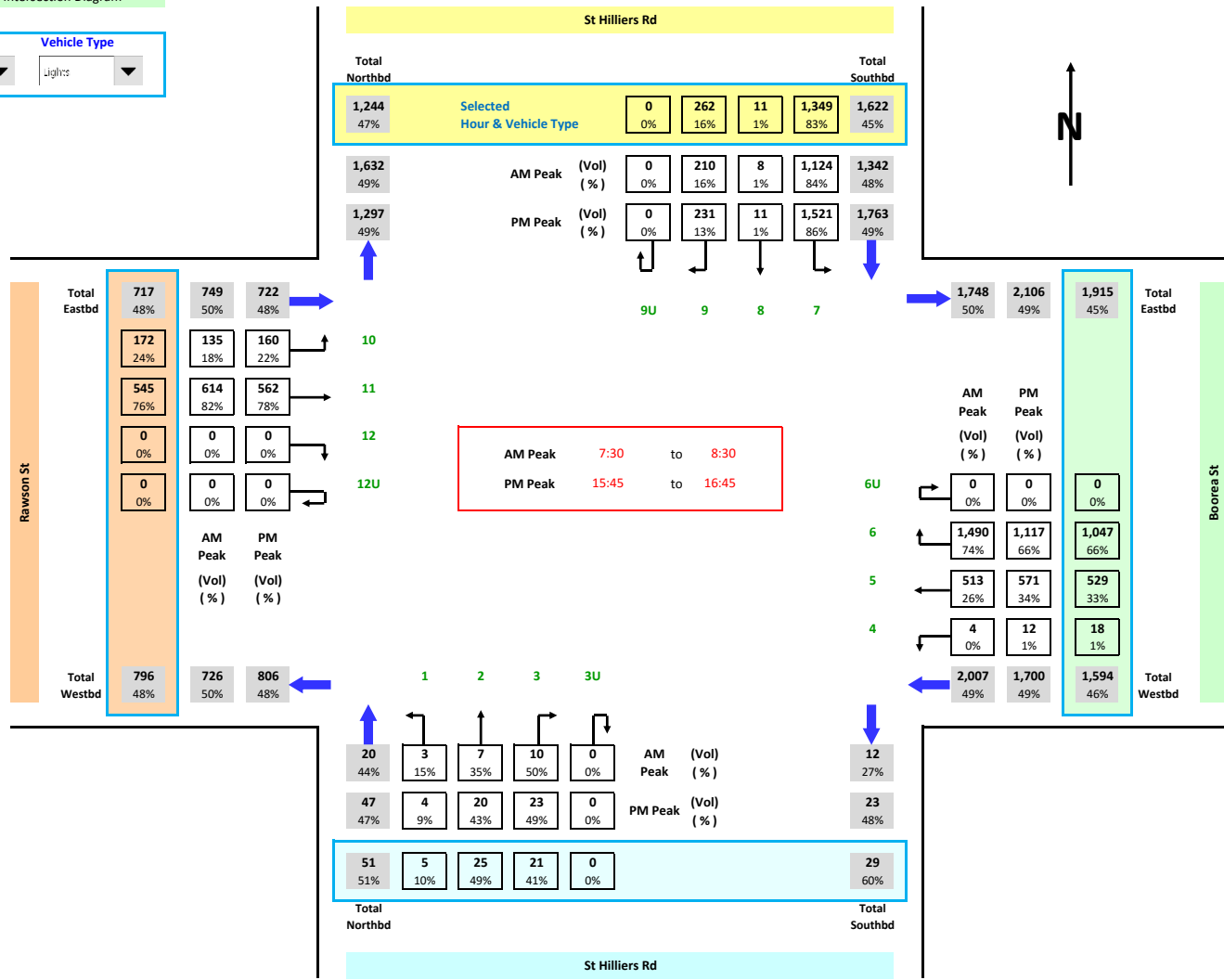

**Job No.** : N3188  
**Client** : GTA  
**Suburb** : Boorea Street  
**Location** : 1. St Hilliers Rd / Boorea St / Rawson St

**Day/Date** : Tuesday, 2nd May 2017  
**Weather** : Fine  
**Description** : Classified Intersection Count  
 : Intersection Diagram



**Hour Starting** : 15:00  
**Vehicle Type** : Heavies

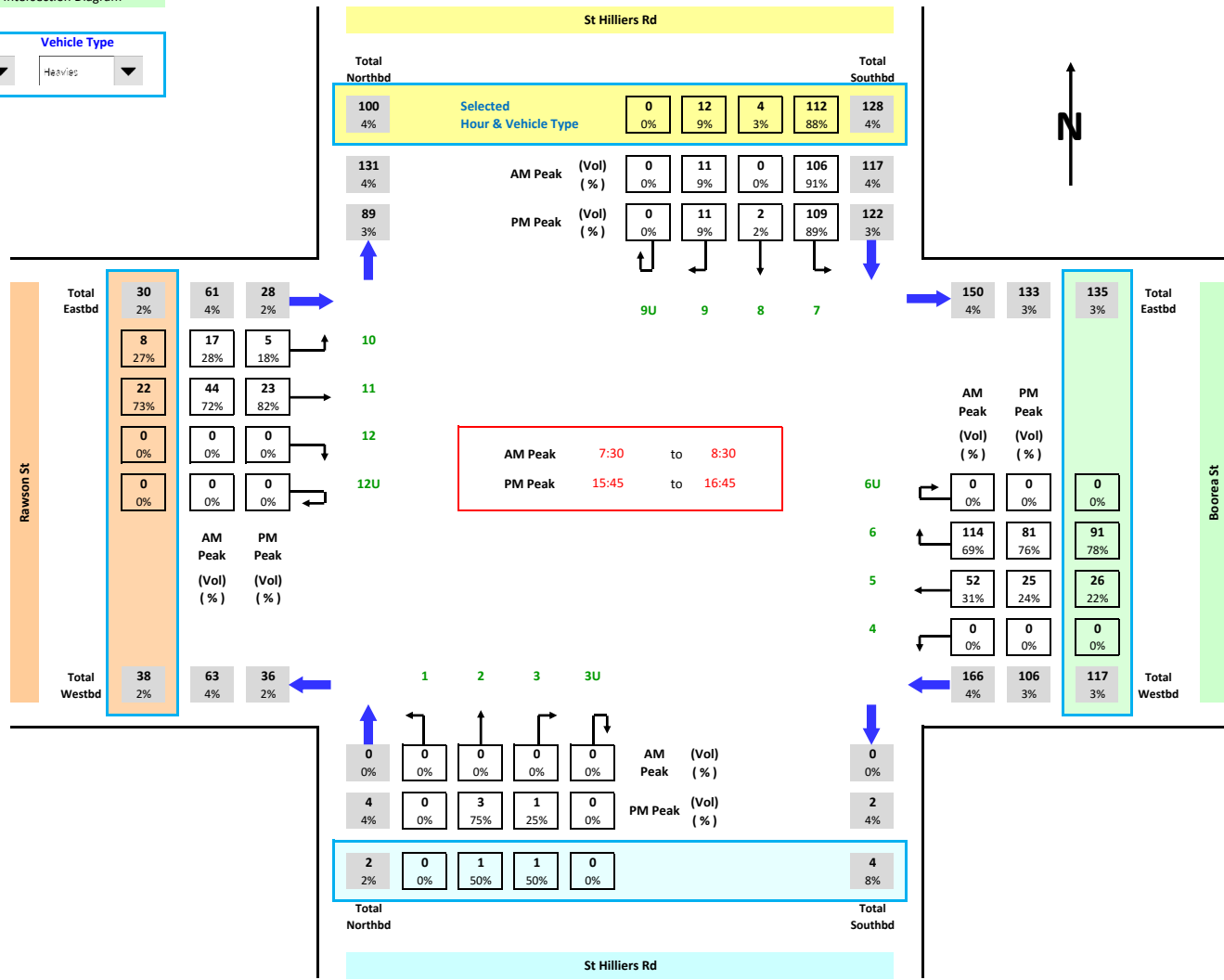

**Job No.** : N3188  
**Client** : GTA  
**Suburb** : Boorea Street  
**Location** : 1. St Hilliers Rd / Boorea St / Rawson St

**Day/Date** : Tuesday, 2nd May 2017  
**Weather** : Fine  
**Description** : Classified Intersection Count  
 : Intersection Diagram



**Hour Starting** : 15:00  
**Vehicle Type** : All Vehicles

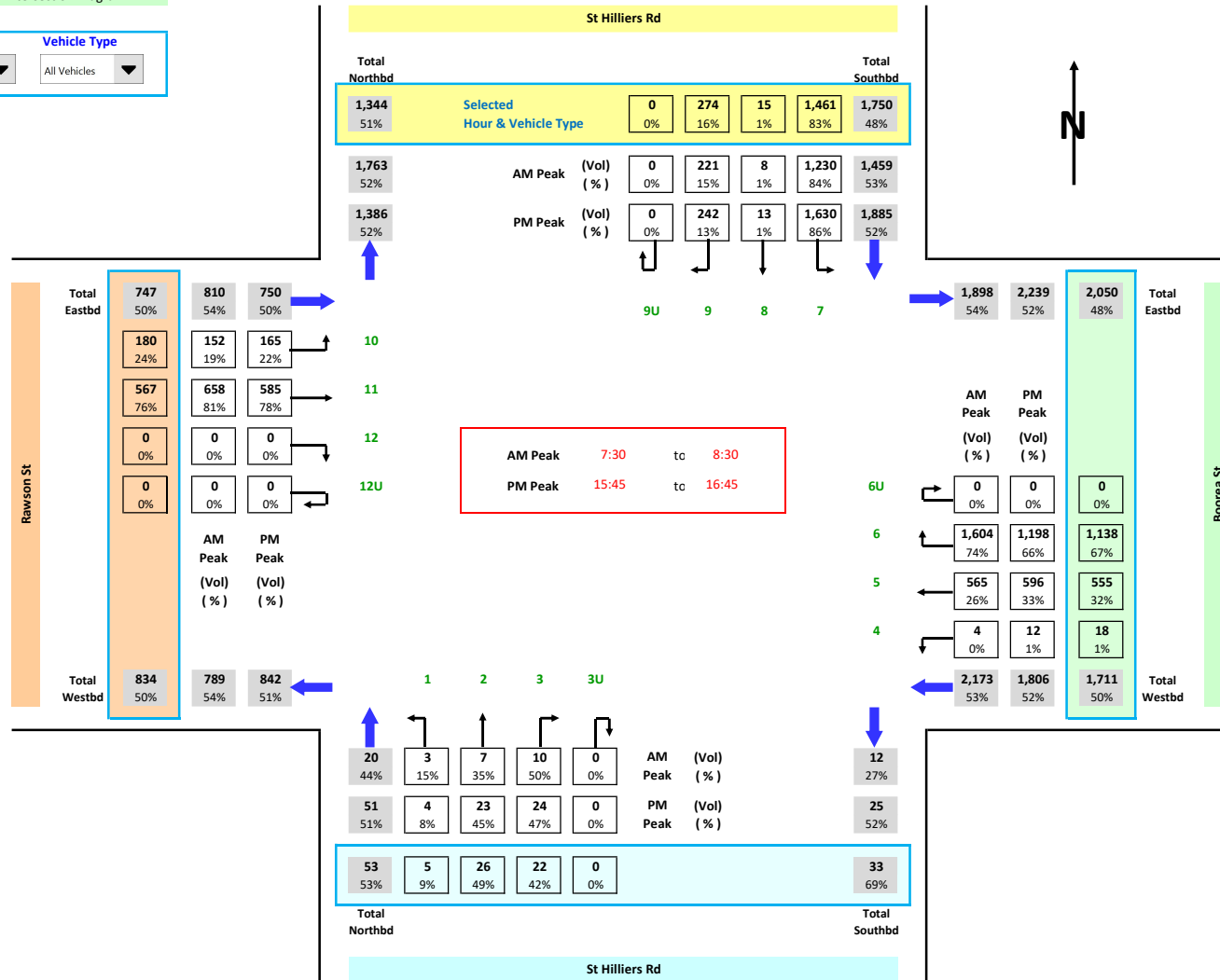

**Job No.** : N3188  
**Client** : GTA  
**Suburb** : Boorea Street  
**Location** : 3. Gelibolu Pde / St Hilliers Rd

**Day/Date** : Tuesday, 2nd May 2017  
**Weather** : Fine  
**Description** : Classified Intersection Count  
: Intersection Diagram



<b>Hour Starting</b>	<b>Vehicle Type</b>
8:00 ▼	Lights ▼

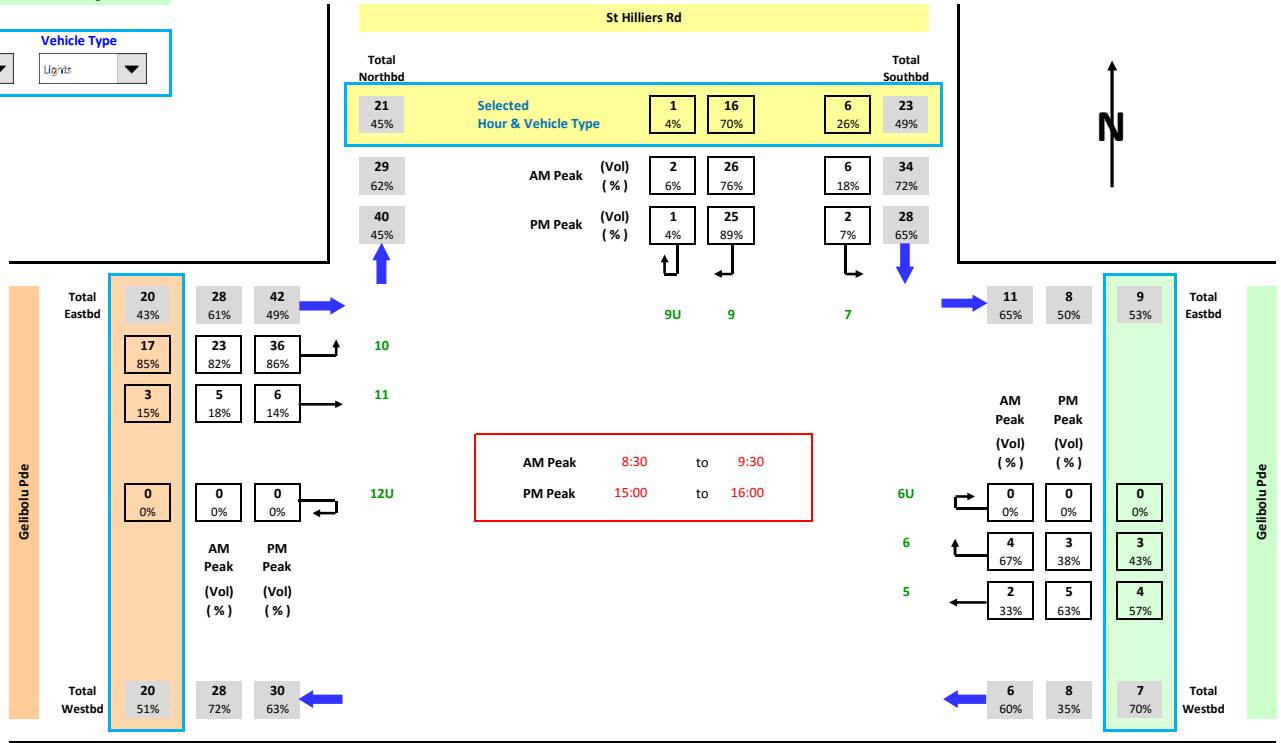

**Job No.** : N3188  
**Client** : GTA  
**Suburb** : Boorea Street  
**Location** : 3. Gelibolu Pde / St Hilliers Rd

**Day/Date** : Tuesday, 2nd May 2017  
**Weather** : Fine  
**Description** : Classified Intersection Count  
: Intersection Diagram



<b>Hour Starting</b>	<b>Vehicle Type</b>
8:00 ▼	Heavies ▼

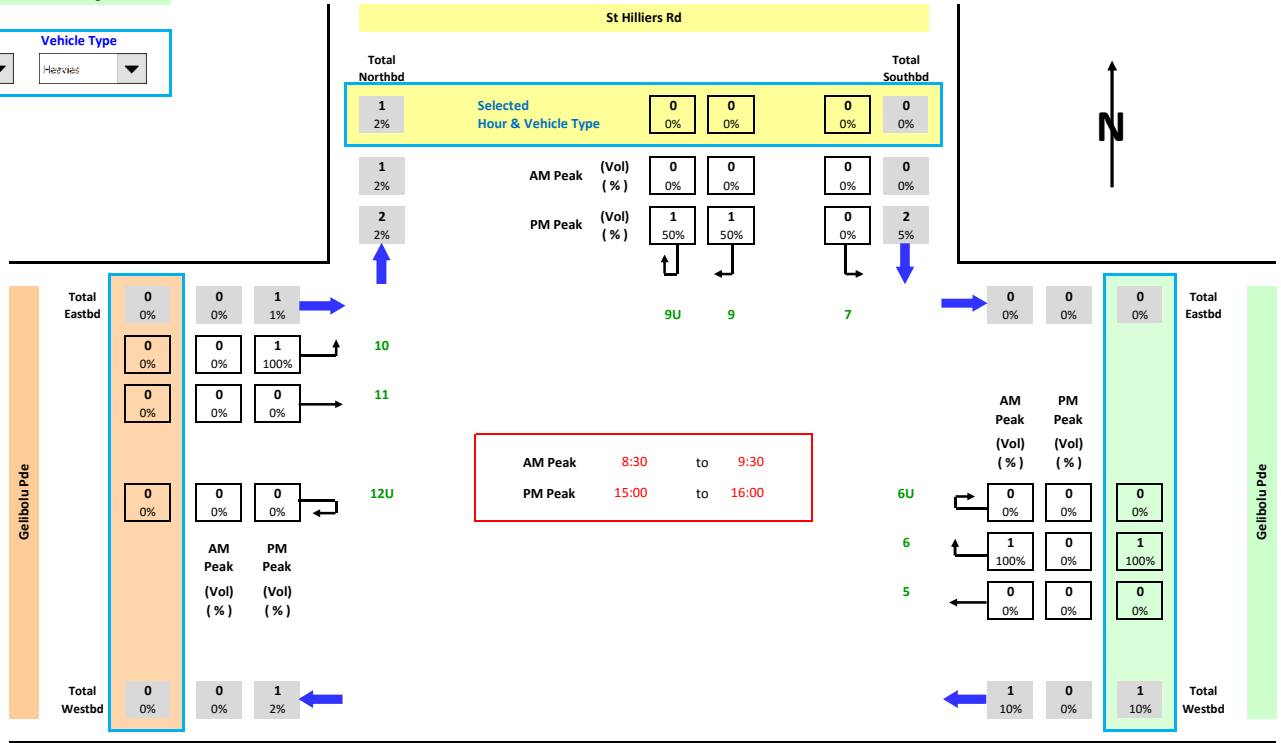

**Job No.** : N3188  
**Client** : GTA  
**Suburb** : Boorea Street  
**Location** : 3. Gelibolu Pde / St Hilliers Rd

**Day/Date** : Tuesday, 2nd May 2017  
**Weather** : Fine  
**Description** : Classified Intersection Count  
 : Intersection Diagram



**Hour Starting** : 8:00  
**Vehicle Type** : All Vehicles

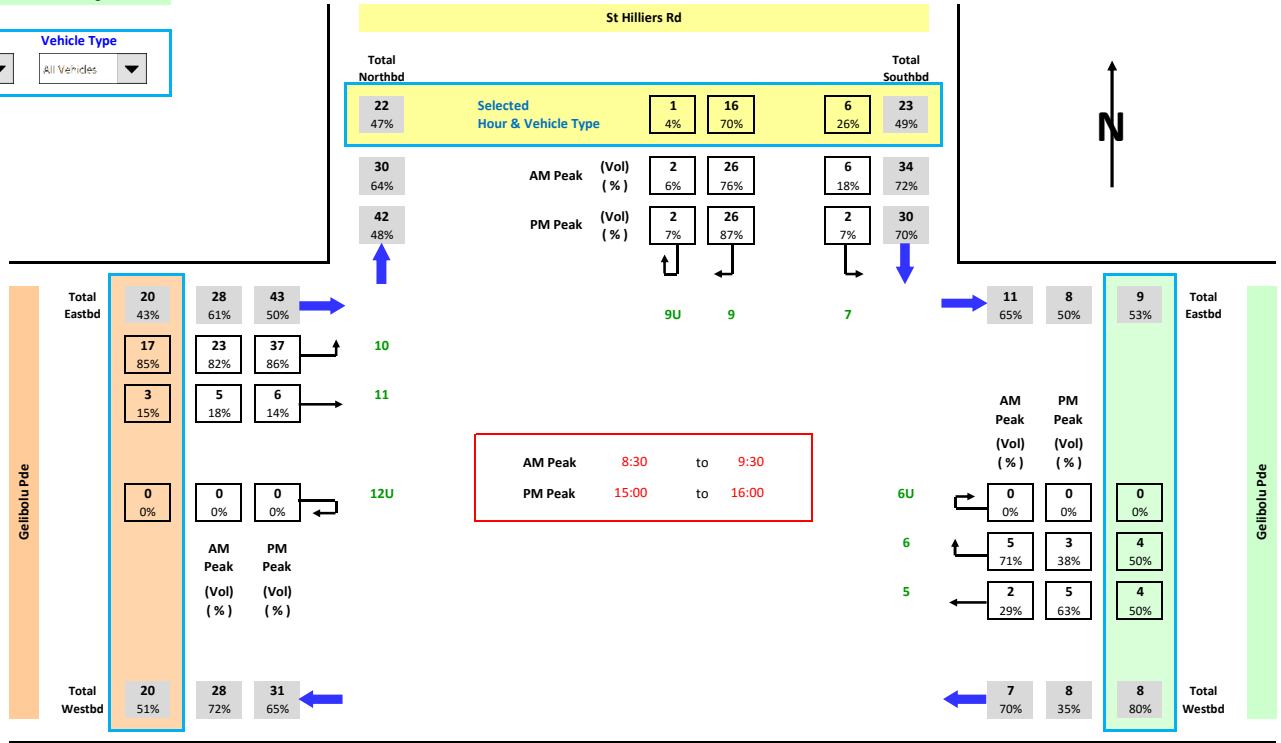

**Job No.** : N3188  
**Client** : GTA  
**Suburb** : Boorea Street  
**Location** : 3. Gelibolu Pde / St Hilliers Rd

**Day/Date** : Tuesday, 2nd May 2017  
**Weather** : Fine  
**Description** : Classified Intersection Count  
: Intersection Diagram



**Hour Starting** : 15:00  
**Vehicle Type** : Lights

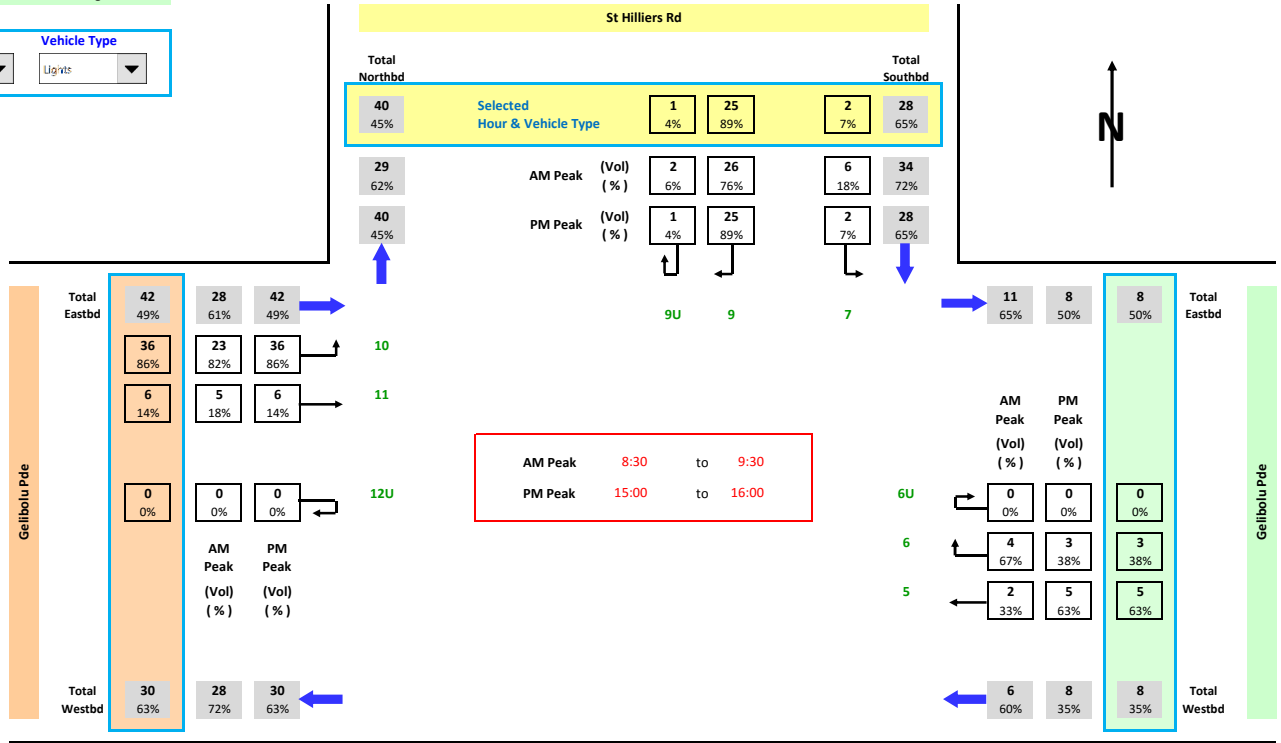



**Job No.** : N3188  
**Client** : GTA  
**Suburb** : Boorea Street  
**Location** : 3. Gelibolu Pde / St Hilliers Rd

**Day/Date** : Tuesday, 2nd May 2017  
**Weather** : Fine  
**Description** : Classified Intersection Count  
: Intersection Diagram



**Hour Starting** : 15:00  
**Vehicle Type** : Heavies

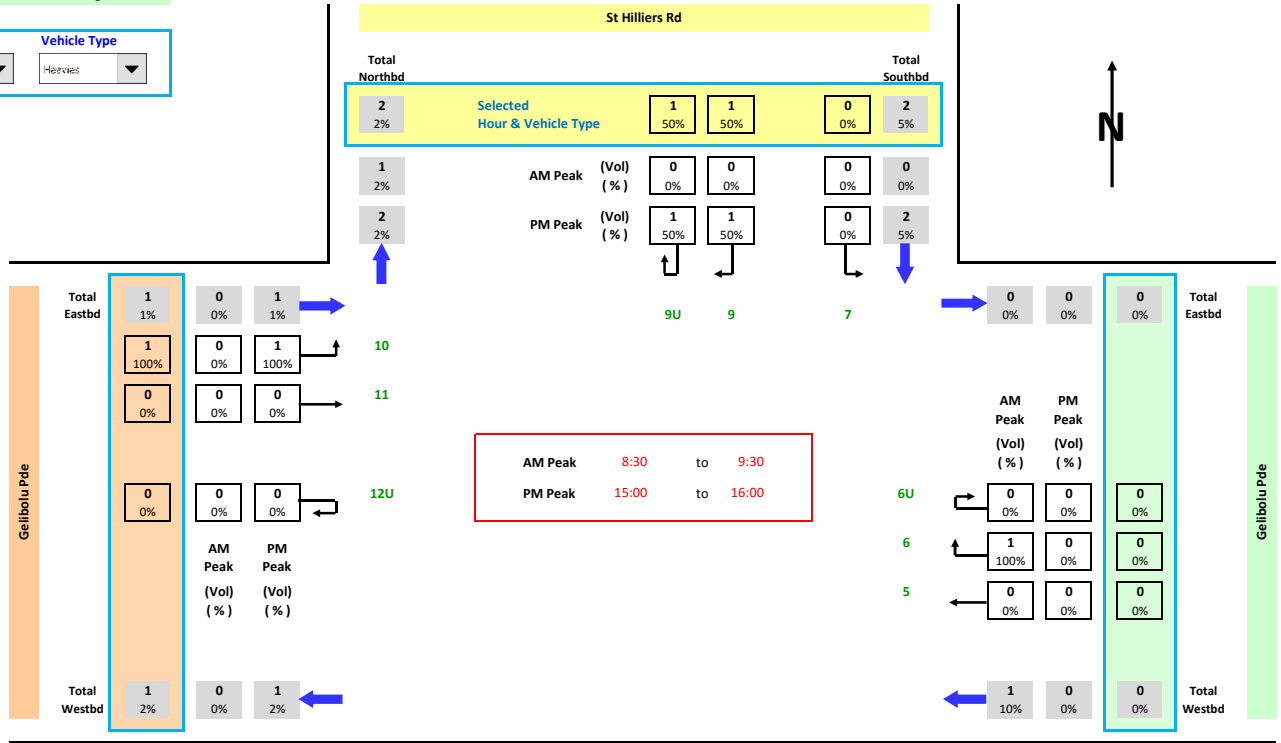

**Job No.** : N3188  
**Client** : GTA  
**Suburb** : Boorea Street  
**Location** : 3. Gelibolu Pde / St Hilliers Rd

**Day/Date** : Tuesday, 2nd May 2017  
**Weather** : Fine  
**Description** : Classified Intersection Count  
 : Intersection Diagram



**Hour Starting** : 15:00  
**Vehicle Type** : All Vehicles

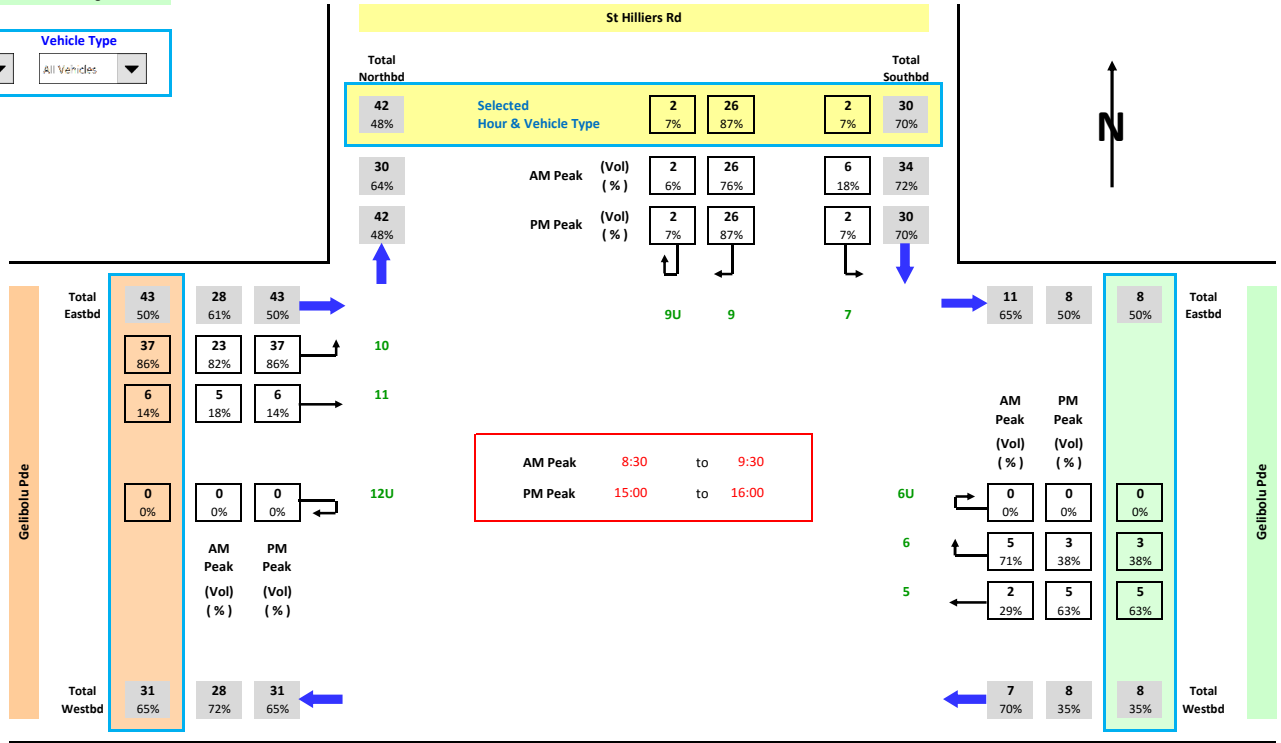

# Appendix B

---

## SIDRA INTERSECTION Results

# MOVEMENT SUMMARY

 **Site: 101 [Boorea Street/ St Hilliers Road AM]**

AM Peak: 7:30am-8:30am

Signals - Fixed Time Isolated Cycle Time = 130 seconds (User-Given Cycle Time)

Variable Sequence Analysis applied. The results are given for the selected output sequence.

Movement Performance - Vehicles											
Mov ID	OD Mov	Demand Total veh/h	Flows HV %	Deg. Satn v/c	Average Delay sec	Level of Service	95% Back of Queue Vehicles veh	Distance m	Prop. Queued	Effective Stop Rate per veh	Average Speed km/h
South: St Hilliers Street											
1a	L1	3	0.0	0.143	72.1	LOS E	0.8	5.7	0.99	0.68	17.8
3a	R1	9	0.0	0.143	71.5	LOS E	0.8	5.7	0.99	0.68	18.2
3b	R3	11	0.0	0.140	74.8	LOS E	0.7	4.8	0.99	0.68	13.3
Approach		23	0.0	0.143	73.1	LOS E	0.8	5.7	0.99	0.68	16.0
SouthEast: Boorea Street											
21b	L3	8	0.0	0.221	13.7	LOS B	6.2	46.7	0.38	0.34	43.0
22	T1	560	8.8	0.221	7.3	LOS A	6.2	47.0	0.38	0.34	45.3
23	R2	1654	7.8	0.752	36.2	LOS D	31.3	233.7	0.87	0.85	22.2
Approach		2222	8.1	0.752	28.8	LOS C	31.3	233.7	0.74	0.72	25.5
NorthEast: St Hilliers Road											
24	L2	1205	10.3	0.566	21.3	LOS C	22.2	169.0	0.64	0.78	29.1
24a	L1	13	8.3	0.595	64.7	LOS E	7.7	56.1	1.00	0.80	18.9
26	R2	234	5.0	0.595	66.4	LOS E	7.7	56.1	1.00	0.80	18.9
Approach		1452	9.4	0.595	29.0	LOS C	22.2	169.0	0.70	0.78	26.0
NorthWest: Rawson Street											
27	L2	169	11.2	0.738	41.8	LOS D	15.4	115.4	0.99	0.93	26.0
28	T1	671	5.3	0.738	49.0	LOS D	17.1	125.2	0.98	0.88	18.7
Approach		840	6.5	0.738	47.5	LOS D	17.1	125.2	0.98	0.89	20.2
All Vehicles		4537	8.2	0.752	32.5	LOS C	31.3	233.7	0.77	0.77	24.4

Site Level of Service (LOS) Method: Delay (SIDRA). Site LOS Method is specified in the Parameter Settings dialog (Site tab).

Vehicle movement LOS values are based on average delay per movement.

Intersection and Approach LOS values are based on average delay for all vehicle movements.

SIDRA Standard Delay Model is used. Control Delay includes Geometric Delay.

Gap-Acceptance Capacity: SIDRA Standard (Akçelik M3D).

HV (%) values are calculated for All Movement Classes of All Heavy Vehicle Model Designation.

Movement Performance - Pedestrians									
Mov ID	Description	Demand Flow ped/h	Average Delay sec	Level of Service	Average Back of Queue Pedestrian ped	Distance m	Prop. Queued	Effective Stop Rate per ped	
P1	South Full Crossing	53	8.2	LOS A	0.1	0.1	0.35	0.35	
P51	SouthEast Stage 1	53	59.3	LOS E	0.2	0.2	0.96	0.96	
P52	SouthEast Stage 2	53	57.4	LOS E	0.2	0.2	0.94	0.94	
P6	NorthEast Full Crossing	53	53.7	LOS E	0.2	0.2	0.91	0.91	
P6S	NorthEast Slip/Bypass Lane Crossing	53	47.5	LOS E	0.2	0.2	0.86	0.86	
All Pedestrians		263	45.2	LOS E			0.80	0.80	

Level of Service (LOS) Method: SIDRA Pedestrian LOS Method (Based on Average Delay)

Pedestrian movement LOS values are based on average delay per pedestrian movement.

Intersection LOS value for Pedestrians is based on average delay for all pedestrian movements.

# MOVEMENT SUMMARY

Site: 101 [Boorea Street/ Percy Street AM]

AM Peak: 7:30am-8:30am  
 Giveway / Yield (Two-Way)

Movement Performance - Vehicles											
Mov ID	OD Mov	Demand Flows Total veh/h	HV %	Deg. Satn v/c	Average Delay sec	Level of Service	95% Back of Queue Vehicles veh	Distance m	Prop. Queued	Effective Stop Rate per veh	Average Speed km/h
South: Percy Street											
1a	L1	5	0.0	0.010	10.0	LOS B	0.0	0.2	0.62	0.73	41.4
Approach		5	0.0	0.010	10.0	LOS B	0.0	0.2	0.62	0.73	41.4
SouthEast: Boorea Street											
21b	L3	5	0.0	0.003	6.8	LOS A	0.0	0.0	0.00	0.58	51.7
22	T1	2245	7.9	0.404	0.0	LOS A	0.0	0.0	0.00	0.00	59.9
Approach		2251	7.9	0.404	0.0	NA	0.0	0.0	0.00	0.00	59.8
All Vehicles		2256	7.9	0.404	0.1	NA	0.0	0.2	0.00	0.00	59.8

Site Level of Service (LOS) Method: Delay (SIDRA). Site LOS Method is specified in the Parameter Settings dialog (Site tab).

Vehicle movement LOS values are based on average delay per movement.

Minor Road Approach LOS values are based on average delay for all vehicle movements.

NA: Intersection LOS and Major Road Approach LOS values are Not Applicable for two-way sign control since the average delay is not a good LOS measure due to zero delays associated with major road movements.

SIDRA Standard Delay Model is used. Control Delay includes Geometric Delay.

Gap-Acceptance Capacity: SIDRA Standard (Akçelik M3D).

HV (%) values are calculated for All Movement Classes of All Heavy Vehicle Model Designation.

SIDRA INTERSECTION 7.0 | Copyright © 2000-2017 Akcelik and Associates Pty Ltd | sidrasolutions.com

Organisation: GTA CONSULTANTS | Processed: Friday, 19 May 2017 11:57:14 AM

Project: \\gta.com.au\projectfiles\ProjectFilesSyd\N12400-12499\N124470 - 2 Percy Street, Auburn\Modelling\170518 N124470 2 Percy Street, Auburn Existing.sip7

# MOVEMENT SUMMARY

▽ Site: 101 [St Hilliers Road/ Gelibolu Parade AM]

AM Peak: 8:30am-9:30am  
Giveway / Yield (Two-Way)

Movement Performance - Vehicles											
Mov ID	OD Mov	Demand Flows		Deg. Satn	Average Delay	Level of Service	95% Back of Queue		Prop. Queued	Effective Stop Rate	Average Speed
		Total veh/h	HV %	v/c	sec		Vehicles veh	Distance m		per veh	km/h
SouthEast: Gelibolu Parade											
22	T1	4	0.0	0.005	0.1	LOS A	0.0	0.2	0.07	0.25	56.3
23a	R1	4	25.0	0.005	4.8	LOS A	0.0	0.2	0.07	0.25	46.1
Approach		8	12.5	0.005	2.4	NA	0.0	0.2	0.07	0.25	51.6
North: St Hilliers Road											
7a	L1	6	0.0	0.004	5.3	LOS A	0.0	0.1	0.02	0.58	45.3
9b	R3	18	0.0	0.014	6.1	LOS A	0.0	0.3	0.07	0.62	49.2
Approach		24	0.0	0.014	5.9	LOS A	0.0	0.3	0.06	0.61	48.4
NorthWest: Gelibolu Parade											
27b	L3	18	0.0	0.013	6.5	LOS A	0.0	0.0	0.00	0.54	51.4
28	T1	3	0.0	0.013	0.0	LOS A	0.0	0.0	0.00	0.54	51.8
Approach		21	0.0	0.013	5.5	NA	0.0	0.0	0.00	0.54	51.5
All Vehicles		54	2.0	0.014	5.2	NA	0.0	0.3	0.04	0.52	50.1

Site Level of Service (LOS) Method: Delay (SIDRA). Site LOS Method is specified in the Parameter Settings dialog (Site tab).

Vehicle movement LOS values are based on average delay per movement.

Minor Road Approach LOS values are based on average delay for all vehicle movements.

NA: Intersection LOS and Major Road Approach LOS values are Not Applicable for two-way sign control since the average delay is not a good LOS measure due to zero delays associated with major road movements.

SIDRA Standard Delay Model is used. Control Delay includes Geometric Delay.

Gap-Acceptance Capacity: SIDRA Standard (Akçelik M3D).

HV (%) values are calculated for All Movement Classes of All Heavy Vehicle Model Designation.

**SIDRA INTERSECTION 7.0 | Copyright © 2000-2017 Akcelik and Associates Pty Ltd | sidrasolutions.com**

Organisation: GTA CONSULTANTS | Processed: Friday, 19 May 2017 11:57:14 AM

Project: \\gta.com.au\projectfiles\ProjectFilesSyd\N12400-12499\N124470 - 2 Percy Street, Auburn\Modelling\170518 N124470 2 Percy Street, Auburn Existing.sip7

# MOVEMENT SUMMARY

 Site: 101 [Boorea Street/ St Hilliers Road PM]

PM Peak: 3:45pm-4:45pm

Signals - Fixed Time Isolated Cycle Time = 130 seconds (User-Given Cycle Time)

Variable Sequence Analysis applied. The results are given for the selected output sequence.

Movement Performance - Vehicles											
Mov ID	OD Mov	Demand Flows		Deg. Satn	Average Delay	Level of Service	95% Back of Queue		Prop. Queued	Effective Stop Rate	Average Speed
		Total veh/h	HV %	v/c	sec		Vehicles veh	Distance m		per veh	km/h
South: St Hilliers Street											
1a	L1	5	0.0	0.378	73.8	LOS E	2.1	15.5	1.00	0.72	17.6
3a	R1	27	3.8	0.378	73.3	LOS E	2.1	15.5	1.00	0.72	17.9
3b	R3	23	4.5	0.318	76.3	LOS E	1.5	11.2	1.00	0.71	13.1
Approach		56	3.8	0.378	74.6	LOS E	2.1	15.5	1.00	0.72	15.9
SouthEast: Boorea Street											
21b	L3	19	0.0	0.254	17.6	LOS B	8.2	59.3	0.47	0.43	38.0
22	T1	584	4.7	0.254	11.1	LOS B	8.3	60.1	0.47	0.42	40.0
23	R2	1198	8.0	0.657	40.8	LOS D	22.7	170.0	0.87	0.83	20.6
Approach		1801	6.8	0.657	30.9	LOS C	22.7	170.0	0.74	0.70	24.6
NorthEast: St Hilliers Road											
24	L2	1538	7.7	0.639	26.4	LOS C	27.4	204.1	0.72	0.81	22.7
24a	L1	16	26.7	0.639	52.4	LOS D	15.1	112.6	0.95	0.83	21.1
26	R2	288	4.4	0.639	57.8	LOS E	15.1	112.6	0.97	0.83	20.7
Approach		1842	7.3	0.639	31.6	LOS C	27.4	204.1	0.76	0.81	22.2
NorthWest: Rawson Street											
27	L2	189	4.4	0.617	28.1	LOS C	11.2	81.1	0.92	0.82	32.3
28	T1	597	3.9	0.617	43.4	LOS D	14.2	102.5	0.95	0.80	20.3
Approach		786	4.0	0.617	39.7	LOS D	14.2	102.5	0.94	0.80	22.9
All Vehicles		4485	6.5	0.657	33.3	LOS C	27.4	204.1	0.79	0.76	23.1

Site Level of Service (LOS) Method: Delay (SIDRA). Site LOS Method is specified in the Parameter Settings dialog (Site tab).

Vehicle movement LOS values are based on average delay per movement.

Intersection and Approach LOS values are based on average delay for all vehicle movements.

SIDRA Standard Delay Model is used. Control Delay includes Geometric Delay.

Gap-Acceptance Capacity: SIDRA Standard (Akçelik M3D).

HV (%) values are calculated for All Movement Classes of All Heavy Vehicle Model Designation.

Movement Performance - Pedestrians									
Mov ID	Description	Demand Flow	Average Delay	Level of Service	Average Back of Queue	Prop. Queued	Effective Stop Rate		
		ped/h	sec		Pedestrian		per ped	Distance	
					ped			m	
P1	South Full Crossing	53	11.7	LOS B	0.1	0.1	0.42	0.42	
P51	SouthEast Stage 1	53	53.7	LOS E	0.2	0.2	0.91	0.91	
P52	SouthEast Stage 2	53	49.2	LOS E	0.2	0.2	0.87	0.87	
P6	NorthEast Full Crossing	53	52.8	LOS E	0.2	0.2	0.90	0.90	
P6S	NorthEast Slip/Bypass Lane Crossing	53	46.6	LOS E	0.2	0.2	0.85	0.85	
All Pedestrians		263	42.8	LOS E			0.79	0.79	

Level of Service (LOS) Method: SIDRA Pedestrian LOS Method (Based on Average Delay)

Pedestrian movement LOS values are based on average delay per pedestrian movement.

Intersection LOS value for Pedestrians is based on average delay for all pedestrian movements.

# MOVEMENT SUMMARY

Site: 101 [Boorea Street/ Percy Street PM]

PM Peak: 3:45pm-4:45pm  
 Giveway / Yield (Two-Way)

Movement Performance - Vehicles											
Mov ID	OD Mov	Demand Total veh/h	Flows HV %	Deg. Satn v/c	Average Delay sec	Level of Service	95% Back of Queue Vehicles veh	Distance m	Prop. Queued	Effective Stop Rate per veh	Average Speed km/h
South: Percy Street											
1a	L1	3	0.0	0.005	8.3	LOS A	0.0	0.1	0.52	0.64	43.3
Approach		3	0.0	0.005	8.3	LOS A	0.0	0.1	0.52	0.64	43.3
SouthEast: Boorea Street											
21b	L3	6	0.0	0.004	6.8	LOS A	0.0	0.0	0.00	0.58	51.7
22	T1	1801	6.8	0.322	0.0	LOS A	0.0	0.0	0.00	0.00	59.9
Approach		1807	6.8	0.322	0.0	NA	0.0	0.0	0.00	0.00	59.9
All Vehicles		1811	6.8	0.322	0.1	NA	0.0	0.1	0.00	0.00	59.8

Site Level of Service (LOS) Method: Delay (SIDRA). Site LOS Method is specified in the Parameter Settings dialog (Site tab).

Vehicle movement LOS values are based on average delay per movement.

Minor Road Approach LOS values are based on average delay for all vehicle movements.

NA: Intersection LOS and Major Road Approach LOS values are Not Applicable for two-way sign control since the average delay is not a good LOS measure due to zero delays associated with major road movements.

SIDRA Standard Delay Model is used. Control Delay includes Geometric Delay.

Gap-Acceptance Capacity: SIDRA Standard (Akçelik M3D).

HV (%) values are calculated for All Movement Classes of All Heavy Vehicle Model Designation.

SIDRA INTERSECTION 7.0 | Copyright © 2000-2017 Akcelik and Associates Pty Ltd | sidrasolutions.com

Organisation: GTA CONSULTANTS | Processed: Friday, 19 May 2017 11:57:16 AM

Project: \\gta.com.au\projectfiles\ProjectFilesSyd\N12400-12499\N124470 - 2 Percy Street, Auburn\Modelling\170518 N124470 2 Percy Street, Auburn Existing.sip7



# MOVEMENT SUMMARY

▽ Site: 101 [St Hilliers Road/ Gelibolu Parade PM]

PM Peak: 3pm-4pm  
Giveway / Yield (Two-Way)

Movement Performance - Vehicles											
Mov ID	OD Mov	Demand Flows		Deg. Satn	Average Delay	Level of Service	95% Back of Queue		Prop. Queued	Effective Stop Rate	Average Speed
		Total veh/h	HV %	v/c	sec		Vehicles veh	Distance m		per veh	km/h
SouthEast: Gelibolu Parade											
22	T1	5	0.0	0.005	0.1	LOS A	0.0	0.1	0.09	0.19	56.6
23a	R1	3	0.0	0.005	4.6	LOS A	0.0	0.1	0.09	0.19	52.3
Approach		8	0.0	0.005	1.8	NA	0.0	0.1	0.09	0.19	55.2
North: St Hilliers Road											
7a	L1	2	50.0	0.002	5.9	LOS A	0.0	0.1	0.04	0.58	39.8
9b	R3	27	3.8	0.022	6.2	LOS A	0.1	0.5	0.09	0.61	48.8
Approach		29	7.1	0.022	6.2	LOS A	0.1	0.5	0.09	0.61	48.4
NorthWest: Gelibolu Parade											
27b	L3	39	2.7	0.028	6.5	LOS A	0.0	0.0	0.00	0.54	50.9
28	T1	6	0.0	0.028	0.0	LOS A	0.0	0.0	0.00	0.54	51.8
Approach		45	2.3	0.028	5.6	NA	0.0	0.0	0.00	0.54	51.0
All Vehicles		83	3.8	0.028	5.4	NA	0.1	0.5	0.04	0.53	50.3

Site Level of Service (LOS) Method: Delay (SIDRA). Site LOS Method is specified in the Parameter Settings dialog (Site tab).

Vehicle movement LOS values are based on average delay per movement.

Minor Road Approach LOS values are based on average delay for all vehicle movements.

NA: Intersection LOS and Major Road Approach LOS values are Not Applicable for two-way sign control since the average delay is not a good LOS measure due to zero delays associated with major road movements.

SIDRA Standard Delay Model is used. Control Delay includes Geometric Delay.

Gap-Acceptance Capacity: SIDRA Standard (Akçelik M3D).

HV (%) values are calculated for All Movement Classes of All Heavy Vehicle Model Designation.

**SIDRA INTERSECTION 7.0 | Copyright © 2000-2017 Akcelik and Associates Pty Ltd | sidrasolutions.com**

Organisation: GTA CONSULTANTS | Processed: Friday, 19 May 2017 11:57:16 AM

Project: \\gta.com.au\projectfiles\ProjectFilesSyd\N12400-12499\N124470 - 2 Percy Street, Auburn\Modelling\170518 N124470 2 Percy Street, Auburn Existing.sip7

# MOVEMENT SUMMARY

▽ Site: 101 [St Hilliers Road/ Gelibolu Parade AM]

AM Peak: 8:30am-9:30am  
Giveway / Yield (Two-Way)

Movement Performance - Vehicles											
Mov ID	OD Mov	Demand Flows		Deg. Satn	Average Delay	Level of Service	95% Back of Queue		Prop. Queued	Effective Stop Rate	Average Speed
		Total veh/h	HV %	v/c	sec		Vehicles veh	Distance m		per veh	km/h
SouthEast: Gelibolu Parade											
22	T1	36	0.0	0.100	0.2	LOS A	0.5	3.5	0.15	0.40	53.5
23a	R1	140	0.8	0.100	4.7	LOS A	0.5	3.5	0.15	0.40	48.4
Approach		176	0.6	0.100	3.8	NA	0.5	3.5	0.15	0.40	49.7
North: St Hilliers Road											
7a	L1	75	0.0	0.047	5.4	LOS A	0.2	1.3	0.10	0.56	44.9
9b	R3	18	0.0	0.017	6.8	LOS A	0.1	0.4	0.27	0.62	48.5
Approach		93	0.0	0.047	5.7	LOS A	0.2	1.3	0.14	0.57	45.9
NorthWest: Gelibolu Parade											
27b	L3	18	0.0	0.030	6.5	LOS A	0.0	0.0	0.00	0.23	54.9
28	T1	34	15.6	0.030	0.0	LOS A	0.0	0.0	0.00	0.23	55.9
Approach		52	10.2	0.030	2.2	NA	0.0	0.0	0.00	0.23	55.5
All Vehicles		320	2.0	0.100	4.1	NA	0.5	3.5	0.12	0.42	49.6

Site Level of Service (LOS) Method: Delay (SIDRA). Site LOS Method is specified in the Parameter Settings dialog (Site tab).

Vehicle movement LOS values are based on average delay per movement.

Minor Road Approach LOS values are based on average delay for all vehicle movements.

NA: Intersection LOS and Major Road Approach LOS values are Not Applicable for two-way sign control since the average delay is not a good LOS measure due to zero delays associated with major road movements.

SIDRA Standard Delay Model is used. Control Delay includes Geometric Delay.

Gap-Acceptance Capacity: SIDRA Standard (Akçelik M3D).

HV (%) values are calculated for All Movement Classes of All Heavy Vehicle Model Designation.

**SIDRA INTERSECTION 7.0 | Copyright © 2000-2017 Akcelik and Associates Pty Ltd | sidrasolutions.com**

Organisation: GTA CONSULTANTS | Processed: Thursday, 18 May 2017 10:19:34 PM

Project: \\gta.com.au\projectfiles\ProjectFilesSyd\N12400-12499\N124470 - 2 Percy Street, Auburn\Modelling\170518 N124470 2 Percy Street, Auburn Future.sip7

# MOVEMENT SUMMARY

 **Site: 101 [Boorea Street/ St Hilliers Road AM]**

AM Peak: 7:30am-8:30am

Signals - Fixed Time Isolated Cycle Time = 130 seconds (User-Given Cycle Time)

Variable Sequence Analysis applied. The results are given for the selected output sequence.

Movement Performance - Vehicles											
Mov ID	OD Mov	Demand Flows		Deg. Satn v/c	Average Delay sec	Level of Service	95% Back of Queue		Prop. Queued	Effective Stop Rate per veh	Average Speed km/h
		Total veh/h	HV %				Vehicles veh	Distance m			
South: St Hilliers Street											
1a	L1	3	0.0	0.437	64.5	LOS E	3.3	23.2	0.97	0.74	19.3
3a	R1	52	0.0	0.437	63.9	LOS E	3.3	23.2	0.97	0.74	19.8
3b	R3	105	0.0	0.824	76.1	LOS E	7.2	50.2	1.00	0.92	13.1
Approach		160	0.0	0.824	72.0	LOS E	7.2	50.2	0.99	0.86	15.3
SouthEast: Boorea Street											
21b	L3	8	0.0	0.246	16.6	LOS B	7.6	57.2	0.45	0.40	39.3
22	T1	574	9.5	0.246	10.2	LOS B	7.6	57.5	0.45	0.40	41.2
23	R2	1687	7.8	0.827	44.3	LOS D	36.3	271.2	0.92	0.90	19.6
Approach		2269	8.2	0.827	35.6	LOS D	36.3	271.2	0.80	0.77	22.6
NorthEast: St Hilliers Road											
24	L2	1205	10.3	0.596	24.0	LOS C	24.0	182.7	0.69	0.80	27.6
24a	L1	75	4.2	0.739	67.8	LOS E	10.1	73.6	1.00	0.87	18.8
26	R2	234	5.0	0.739	69.6	LOS E	10.1	73.6	1.00	0.86	18.4
Approach		1514	9.2	0.739	33.2	LOS C	24.0	182.7	0.75	0.81	24.4
NorthWest: Rawson Street											
27	L2	169	11.2	0.826	50.8	LOS D	17.7	132.5	1.00	1.01	23.2
28	T1	671	5.3	0.826	56.8	LOS E	18.3	133.9	0.99	0.96	16.9
Approach		840	6.5	0.826	55.6	LOS E	18.3	133.9	0.99	0.97	18.2
All Vehicles		4783	7.9	0.827	39.5	LOS D	36.3	271.2	0.83	0.82	21.8

Site Level of Service (LOS) Method: Delay (SIDRA). Site LOS Method is specified in the Parameter Settings dialog (Site tab).

Vehicle movement LOS values are based on average delay per movement.

Intersection and Approach LOS values are based on average delay for all vehicle movements.

SIDRA Standard Delay Model is used. Control Delay includes Geometric Delay.

Gap-Acceptance Capacity: SIDRA Standard (Akçelik M3D).

HV (%) values are calculated for All Movement Classes of All Heavy Vehicle Model Designation.

Movement Performance - Pedestrians									
Mov ID	Description	Demand Flow ped/h	Average Delay sec	Level of Service	Average Back of Queue		Prop. Queued	Effective Stop Rate per ped	
					Pedestrian ped	Distance m			
P1	South Full Crossing	53	10.8	LOS B	0.1	0.1	0.41	0.41	
P51	SouthEast Stage 1	53	59.3	LOS E	0.2	0.2	0.96	0.96	
P52	SouthEast Stage 2	53	57.4	LOS E	0.2	0.2	0.94	0.94	
P6	NorthEast Full Crossing	53	56.4	LOS E	0.2	0.2	0.93	0.93	
P6S	NorthEast Slip/Bypass Lane Crossing	53	50.1	LOS E	0.2	0.2	0.88	0.88	
All Pedestrians		263	46.8	LOS E			0.82	0.82	

Level of Service (LOS) Method: SIDRA Pedestrian LOS Method (Based on Average Delay)

Pedestrian movement LOS values are based on average delay per pedestrian movement.

Intersection LOS value for Pedestrians is based on average delay for all pedestrian movements.

# MOVEMENT SUMMARY

Site: 101 [Boorea Street/ Percy Street AM]

AM Peak: 7:30am-8:30am  
 Giveway / Yield (Two-Way)

Movement Performance - Vehicles											
Mov ID	OD Mov	Demand Total veh/h	Flows HV %	Deg. Satn v/c	Average Delay sec	Level of Service	95% Back of Queue Vehicles veh	Distance m	Prop. Queued	Effective Stop Rate per veh	Average Speed km/h
South: Percy Street											
1a	L1	44	16.7	0.102	11.9	LOS B	0.3	2.7	0.67	0.86	39.4
Approach		44	16.7	0.102	11.9	LOS B	0.3	2.7	0.67	0.86	39.4
SouthEast: Boorea Street											
21b	L3	86	4.9	0.055	6.9	LOS A	0.0	0.0	0.00	0.58	51.6
22	T1	2245	7.9	0.404	0.0	LOS A	0.0	0.0	0.00	0.00	59.9
Approach		2332	7.8	0.404	0.3	NA	0.0	0.0	0.00	0.02	59.3
All Vehicles		2376	8.0	0.404	0.5	NA	0.3	2.7	0.01	0.04	58.6

Site Level of Service (LOS) Method: Delay (SIDRA). Site LOS Method is specified in the Parameter Settings dialog (Site tab).

Vehicle movement LOS values are based on average delay per movement.

Minor Road Approach LOS values are based on average delay for all vehicle movements.

NA: Intersection LOS and Major Road Approach LOS values are Not Applicable for two-way sign control since the average delay is not a good LOS measure due to zero delays associated with major road movements.

SIDRA Standard Delay Model is used. Control Delay includes Geometric Delay.

Gap-Acceptance Capacity: SIDRA Standard (Akçelik M3D).

HV (%) values are calculated for All Movement Classes of All Heavy Vehicle Model Designation.

SIDRA INTERSECTION 7.0 | Copyright © 2000-2017 Akcelik and Associates Pty Ltd | sidrasolutions.com

Organisation: GTA CONSULTANTS | Processed: Thursday, 18 May 2017 10:30:48 PM

Project: \\gta.com.au\projectfiles\ProjectFilesSyd\N12400-12499\N124470 - 2 Percy Street, Auburn\Modelling\170518 N124470 2 Percy Street, Auburn Future.sip7

# MOVEMENT SUMMARY

 **Site: 101 [Boorea Street/ St Hilliers Road PM]**

PM Peak: 3:45pm-4:45pm

Signals - Fixed Time Isolated Cycle Time = 130 seconds (User-Given Cycle Time)

Variable Sequence Analysis applied. The results are given for the selected output sequence.

Movement Performance - Vehicles											
Mov ID	OD Mov	Demand Flows		Deg. Satn v/c	Average Delay sec	Level of Service	95% Back of Queue		Prop. Queued	Effective Stop Rate per veh	Average Speed km/h
		Total veh/h	HV %				Vehicles veh	Distance m			
South: St Hilliers Street											
1a	L1	5	0.0	0.504	62.6	LOS E	3.9	28.0	0.96	0.74	19.7
3a	R1	61	1.7	0.504	62.0	LOS E	3.9	28.0	0.96	0.74	20.1
3b	R3	100	1.1	0.717	69.4	LOS E	6.4	45.1	0.99	0.85	14.1
Approach		166	1.3	0.717	66.5	LOS E	6.4	45.1	0.98	0.81	16.4
SouthEast: Boorea Street											
21b	L3	19	0.0	0.286	21.2	LOS C	9.7	70.8	0.54	0.49	34.4
22	T1	600	5.4	0.286	14.7	LOS B	9.8	71.7	0.54	0.48	36.2
23	R2	1225	8.0	0.738	45.2	LOS D	24.9	186.5	0.92	0.85	19.3
Approach		1844	7.1	0.738	35.0	LOS D	24.9	186.5	0.79	0.73	22.9
NorthEast: St Hilliers Road											
24	L2	1538	7.7	0.724	30.2	LOS C	33.1	246.9	0.81	0.84	21.3
24a	L1	92	6.9	0.724	57.5	LOS E	16.1	119.3	0.99	0.86	20.7
26	R2	288	4.4	0.724	62.2	LOS E	16.1	119.3	1.00	0.86	19.8
Approach		1918	7.1	0.724	36.3	LOS D	33.1	246.9	0.85	0.85	21.0
NorthWest: Rawson Street											
27	L2	189	4.4	0.671	28.4	LOS C	10.0	72.6	0.93	0.82	32.0
28	T1	597	3.9	0.671	47.3	LOS D	14.1	102.1	0.97	0.82	19.2
Approach		786	4.0	0.671	42.8	LOS D	14.1	102.1	0.96	0.82	21.9
All Vehicles		4715	6.4	0.738	37.9	LOS D	33.1	246.9	0.85	0.80	21.6

Site Level of Service (LOS) Method: Delay (SIDRA). Site LOS Method is specified in the Parameter Settings dialog (Site tab).

Vehicle movement LOS values are based on average delay per movement.

Intersection and Approach LOS values are based on average delay for all vehicle movements.

SIDRA Standard Delay Model is used. Control Delay includes Geometric Delay.

Gap-Acceptance Capacity: SIDRA Standard (Akçelik M3D).

HV (%) values are calculated for All Movement Classes of All Heavy Vehicle Model Designation.

Movement Performance - Pedestrians									
Mov ID	Description	Demand Flow ped/h	Average Delay sec	Level of Service	Average Back of Queue		Prop. Queued	Effective Stop Rate per ped	
					Pedestrian ped	Distance m			
P1	South Full Crossing	53	14.8	LOS B	0.1	0.1	0.48	0.48	
P51	SouthEast Stage 1	53	55.5	LOS E	0.2	0.2	0.93	0.93	
P52	SouthEast Stage 2	53	51.0	LOS E	0.2	0.2	0.89	0.89	
P6	NorthEast Full Crossing	53	55.5	LOS E	0.2	0.2	0.93	0.93	
P6S	NorthEast Slip/Bypass Lane Crossing	53	49.2	LOS E	0.2	0.2	0.87	0.87	
All Pedestrians		263	45.2	LOS E			0.82	0.82	

Level of Service (LOS) Method: SIDRA Pedestrian LOS Method (Based on Average Delay)

Pedestrian movement LOS values are based on average delay per pedestrian movement.

Intersection LOS value for Pedestrians is based on average delay for all pedestrian movements.

# MOVEMENT SUMMARY

Site: 101 [Boorea Street/ Percy Street PM]

PM Peak: 3:45pm-4:45pm  
 Giveway / Yield (Two-Way)

Movement Performance - Vehicles											
Mov ID	OD Mov	Demand Flows		Deg. Satn	Average Delay	Level of Service	95% Back of Queue		Prop. Queued	Effective Stop Rate	Average Speed
		Total veh/h	HV %	v/c	sec		Vehicles veh	Distance m		per veh	km/h
South: Percy Street											
1a	L1	36	20.6	0.065	9.7	LOS A	0.2	1.8	0.56	0.78	41.6
Approach		36	20.6	0.065	9.7	LOS A	0.2	1.8	0.56	0.78	41.6
SouthEast: Boorea Street											
21b	L3	105	4.0	0.066	6.9	LOS A	0.0	0.0	0.00	0.58	51.6
22	T1	1801	6.8	0.322	0.0	LOS A	0.0	0.0	0.00	0.00	59.9
Approach		1906	6.7	0.322	0.4	NA	0.0	0.0	0.00	0.03	59.0
All Vehicles		1942	6.9	0.322	0.6	NA	0.2	1.8	0.01	0.05	58.4

Site Level of Service (LOS) Method: Delay (SIDRA). Site LOS Method is specified in the Parameter Settings dialog (Site tab).

Vehicle movement LOS values are based on average delay per movement.

Minor Road Approach LOS values are based on average delay for all vehicle movements.

NA: Intersection LOS and Major Road Approach LOS values are Not Applicable for two-way sign control since the average delay is not a good LOS measure due to zero delays associated with major road movements.

SIDRA Standard Delay Model is used. Control Delay includes Geometric Delay.

Gap-Acceptance Capacity: SIDRA Standard (Akçelik M3D).

HV (%) values are calculated for All Movement Classes of All Heavy Vehicle Model Designation.

SIDRA INTERSECTION 7.0 | Copyright © 2000-2017 Akcelik and Associates Pty Ltd | sidrasolutions.com

Organisation: GTA CONSULTANTS | Processed: Thursday, 18 May 2017 10:30:20 PM

Project: \\gta.com.au\projectfiles\ProjectFilesSyd\N12400-12499\N124470 - 2 Percy Street, Auburn\Modelling\170518 N124470 2 Percy Street, Auburn Future.sip7

# MOVEMENT SUMMARY

▽ Site: 101 [St Hilliers Road/ Gelibolu Parade PM]

PM Peak: 3pm-4pm  
Giveway / Yield (Two-Way)

Movement Performance - Vehicles											
Mov ID	OD Mov	Demand Flows		Deg. Satn	Average Delay	Level of Service	95% Back of Queue		Prop. Queued	Effective Stop Rate	Average Speed
		Total veh/h	HV %	v/c	sec		Vehicles veh	Distance m		per veh	km/h
SouthEast: Gelibolu Parade											
22	T1	31	0.0	0.084	0.2	LOS A	0.4	2.8	0.19	0.39	53.3
23a	R1	114	0.0	0.084	4.8	LOS A	0.4	2.8	0.19	0.39	48.4
Approach		144	0.0	0.084	3.8	NA	0.4	2.8	0.19	0.39	49.6
North: St Hilliers Road											
7a	L1	86	1.2	0.055	5.5	LOS A	0.2	1.6	0.12	0.56	44.7
9b	R3	27	3.8	0.026	6.8	LOS A	0.1	0.6	0.27	0.62	48.3
Approach		114	1.9	0.055	5.8	LOS A	0.2	1.6	0.16	0.57	45.9
NorthWest: Gelibolu Parade											
27b	L3	39	2.7	0.048	6.5	LOS A	0.0	0.0	0.00	0.31	53.9
28	T1	43	12.2	0.048	0.0	LOS A	0.0	0.0	0.00	0.31	54.9
Approach		82	7.7	0.048	3.1	NA	0.0	0.0	0.00	0.31	54.4
All Vehicles		340	2.5	0.084	4.3	NA	0.4	2.8	0.13	0.43	49.7

Site Level of Service (LOS) Method: Delay (SIDRA). Site LOS Method is specified in the Parameter Settings dialog (Site tab).

Vehicle movement LOS values are based on average delay per movement.

Minor Road Approach LOS values are based on average delay for all vehicle movements.

NA: Intersection LOS and Major Road Approach LOS values are Not Applicable for two-way sign control since the average delay is not a good LOS measure due to zero delays associated with major road movements.

SIDRA Standard Delay Model is used. Control Delay includes Geometric Delay.

Gap-Acceptance Capacity: SIDRA Standard (Akçelik M3D).

HV (%) values are calculated for All Movement Classes of All Heavy Vehicle Model Designation.

**SIDRA INTERSECTION 7.0 | Copyright © 2000-2017 Akcelik and Associates Pty Ltd | sidrasolutions.com**

Organisation: GTA CONSULTANTS | Processed: Thursday, 18 May 2017 10:31:10 PM

Project: \\gta.com.au\projectfiles\ProjectFilesSyd\N12400-12499\N124470 - 2 Percy Street, Auburn\Modelling\170518 N124470 2 Percy Street, Auburn Future.sip7

# Appendix C

---

## Proposed School Program



09 May 2017

**Project School: Educational Establishment**

**Address: 2 Percy Street, Auburn**

**Total Number of Students: 650**

**From Kinder to Year 12**

**Proposed School Program**

**1. Kindergarden and Primary School – Total of 350 students**

- 1.1. Assembly area
- 1.2. Kindergarden – 2 Classes (25 students each) – Total of 50 students
- 1.3. 1 Year to 6 – 12 classes (25 students each) – Total of 300 students
- 1.4. One large Staff room with Kitchenette + Toilets
- 1.5. Library + Printer room + Admin office
- 1.6. 1 Resource Room
- 1.7. 1 Support Room – For kids with special needs
- 1.8. Small Multi-purpose Room + Storage (For music, dance classes and additional activities)
- 1.9. Computer Lab / Language Room
- 1.10. Art Room + Storage (large space for desks and sitting area) – with access to outdoor area
- 1.11. 2 Kindy Bathrooms (one for girls and one for boys)
- 1.12. Staff Toilets
- 1.13. 2 Primary Students Toilets ( one for girls and one for boys)
- 1.14. Cleaner room (with sink)
- 1.15. Coordinator's Office (large office with meeting area)
- 1.16. Drop off and Pick area for Kindergarden

**2. Secondary School – Total of 300 students**

- 2.1. Assembly area
- 2.2. 7 Year to 12 – 12 classes (25 students each) – Total of 300 students
- 2.3. 2 Toilets (one for girls and one for boys)
- 2.4. Staff Toilets

- 2.5. Library + Computer area + Printer room + Admin Office
- 2.6. 5 Labs + Resource Room/ Storage Area ( Science, Physics and Biology, Chemistry, Computer, Technological and Applied Studies)
- 2.7. Lockers (Outside the classes)
- 2.8. Coordinator's Office (large office with meeting area)
- 2.9. 1 Large Staff Room with Kitchenette + Toilets
- 2.10. 8 Teachers Room – One for each Major subject (English; Mathematics; Science; Human society and its environment; personal development, creative arts; technology and Arabic)
- 2.11. Counsellor's office
- 2.12. Cleaner room (with sink)

### **3. Administration area**

- 3.1. Principal Office
- 3.2. Deputy Principal
- 3.3. Director
- 3.4. Maarif President
- 3.5. 2 Meeting room
- 3.6. 2 Small Interview's room
- 3.7. Accounts Room
- 3.8. IT Room + Server Room
- 3.9. Reception + Printer Room + Storage
- 3.10. Kitchenette + Tea Room
- 3.11. Toilets
- 3.12. Cleaner room (with sink)

### **4. School Facilities**

- 4.1. Multi-Purpose Hall (gymnasium) + Toilets (including showers and changing area)
- 4.2. Toilets
- 4.3. Prayer Mescit + wudu room
- 4.4. Chaplains Room
- 4.5. Canteen + Cafeteria
- 4.6. Outdoor Playground
- 4.7. Gym
- 4.8. Sport's Room (Storage)
- 4.9. Maintenance Room (Storage)
- 4.10. Uniform Shop
- 4.11. 1 First Aid Room (Sick Bay)
- 4.12. Staff Parking
- 4.13. Public Parking
- 4.14. Drop off and Pick up area for School Buses
- 4.15. Drop off and Pick area for small vehicles

Melbourne

A Level 25, 55 Collins Street  
PO Box 24055  
MELBOURNE VIC 3000  
P +613 9851 9600  
E melbourne@gta.com.au

Sydney

A Level 6, 15 Help Street  
CHATSWOOD NSW 2067  
PO Box 5254  
WEST CHATSWOOD NSW 1515  
P +612 8448 1800  
E sydney@gta.com.au

Brisbane

A Ground Floor, 283 Elizabeth Street  
BRISBANE QLD 4000  
GPO Box 115  
BRISBANE QLD 4001  
P +617 3113 5000  
E brisbane@gta.com.au

Canberra

A Tower A, Level 5,  
7 London Circuit  
Canberra ACT 2600  
P +612 6243 4826  
E canberra@gta.com.au

Adelaide

A Suite 4, Level 1, 136 The Parade  
PO Box 3421  
NORWOOD SA 5067  
P +618 8334 3600  
E adelaide@gta.com.au

Gold Coast

A Level 9, Corporate Centre 2  
Box 37, 1 Corporate Court  
BUNDALL QLD 4217  
P +617 5510 4800  
F +617 5510 4814  
E goldcoast@gta.com.au

Townsville

A Level 1, 25 Sturt Street  
PO Box 1064  
TOWNSVILLE QLD 4810  
P +617 4722 2765  
E townsville@gta.com.au

Perth

A Level 2, 5 Mill Street  
PERTH WA 6000  
PO Box 7025, Cloisters Square  
PERTH WA 6850  
P +618 6169 1000  
E perth@gta.com.au